



# Standard Test Methods for Impact Resistance of Rigid Poly(Vinyl Chloride) (PVC) Building Products<sup>1</sup>

This standard is issued under the fixed designation D 4226; the number immediately following the designation indicates the year of original adoption or, in the case of revision, the year of last revision. A number in parentheses indicates the year of last reapproval. A superscript epsilon ( $\epsilon$ ) indicates an editorial change since the last revision or reapproval.

## 1. Scope \*

1.1 These test methods cover the determination of the energy required to crack or break rigid poly(vinyl chloride) (PVC) plastic sheeting and profile flat sections used in building products, as well as extruded or molded test samples, under specified conditions of impact from a freefalling standard weight striking an impactor with either of two configurations in contact with the specimen.

1.2 Two test procedures are included:

1.2.1 *Procedure A*, used to determine minimum impact energy required to cause failure (hole, crack, split, shatter, or tear).

1.2.2 *Procedure B*, used to determine minimum impact energy required to cause brittle failure.

1.3 The values in inch-pound units are to be regarded as the standard.

NOTE 1—There is no similar or equivalent ISO standard.

1.4 The text of this standard references notes and footnotes which provide explanatory material. These notes and footnotes (excluding, those in tables in figures) shall not be considered as requirements of this standard.

1.5 *This standard does not purport to address all of the safety concerns, if any, associated with its use. It is the responsibility of the user of this standard to establish appropriate safety and health practices and determine the applicability of regulatory limitations prior to use.* Specific precautionary statements are given in Section 8.

## 2. Referenced Documents

2.1 *ASTM Standards:*

D 374 Test Methods for Thickness of Solid Electrical Insulation<sup>2</sup>

D 618 Practice for Conditioning Plastics and Electrical Insulating Materials for Testing<sup>3</sup>

D 883 Terminology Relating to Plastics<sup>3</sup>

D 1898 Practice for Sampling of Plastics<sup>4</sup>

D 3679 Specification for Rigid Poly(Vinyl Chloride) (PVC) Siding<sup>5</sup>

E 178 Practice for Dealing with Outlying Observations<sup>6</sup>

## 3. Terminology

3.1 *Definitions*—Definitions are in accordance with Terminology D 883, unless otherwise indicated.

3.2 *Definitions of Terms Specific to This Standard:*

3.2.1 *failure (of test specimen)*—signified by the presence of a punched hole, crack, split, shatter, or tear that was created in the target area by the impact of the falling weight and is clearly visible to the naked eye when the sample is held up to the light (see Fig. 1).

3.2.2 *brittle failure*—a punched hole, split, or shatter where a piece of the specimen separates from the main part of the specimen or a crack that has a 0° angle at the tip as measured by the naked eye (see Fig. 1).

3.2.3 *mean failure height (Procedure A)*—the height from which the falling weight will cause 50 % of the specimens to fail.

3.2.4 *mean failure energy (mean impact resistance)*, (Procedure A)—energy required to produce 50 % failures; the product of the weight and mean failure height.

3.2.5 *normalized mean failure energy (normalized mean impact resistance)*—the mean failure energy per unit (average) specimen thickness (Procedure A).

3.2.6 *mean brittle failure height*—the height from which the falling weight will cause 50 % brittle failures in specimens (Procedure B).

3.2.7 *mean brittle failure energy (mean energy of ductile-to-brittle transition)*, (Procedure B)—energy required to produce 50 % brittle failures; the product of the weight and mean brittle failure height.

<sup>1</sup> These test methods are under the jurisdiction of ASTM Committee D20 on Plastics and are the direct responsibility of Subcommittee D20.24 on Plastic Building Products.

Current edition approved Dec. 10, 2000. Published February 2001. Originally published as D 4226 - 83. Last previous edition D 4226 - 99.

<sup>2</sup> *Annual Book of ASTM Standards*, Vol 10.01.

<sup>3</sup> *Annual Book of ASTM Standards*, Vol 08.01.

<sup>4</sup> *Annual Book of ASTM Standards*, Vol 03.06.

<sup>5</sup> *Annual Book of ASTM Standards*, Vol 08.04.

<sup>6</sup> *Annual Book of ASTM Standards*, Vol 14.02.

\*A Summary of Changes section appears at the end of this standard.

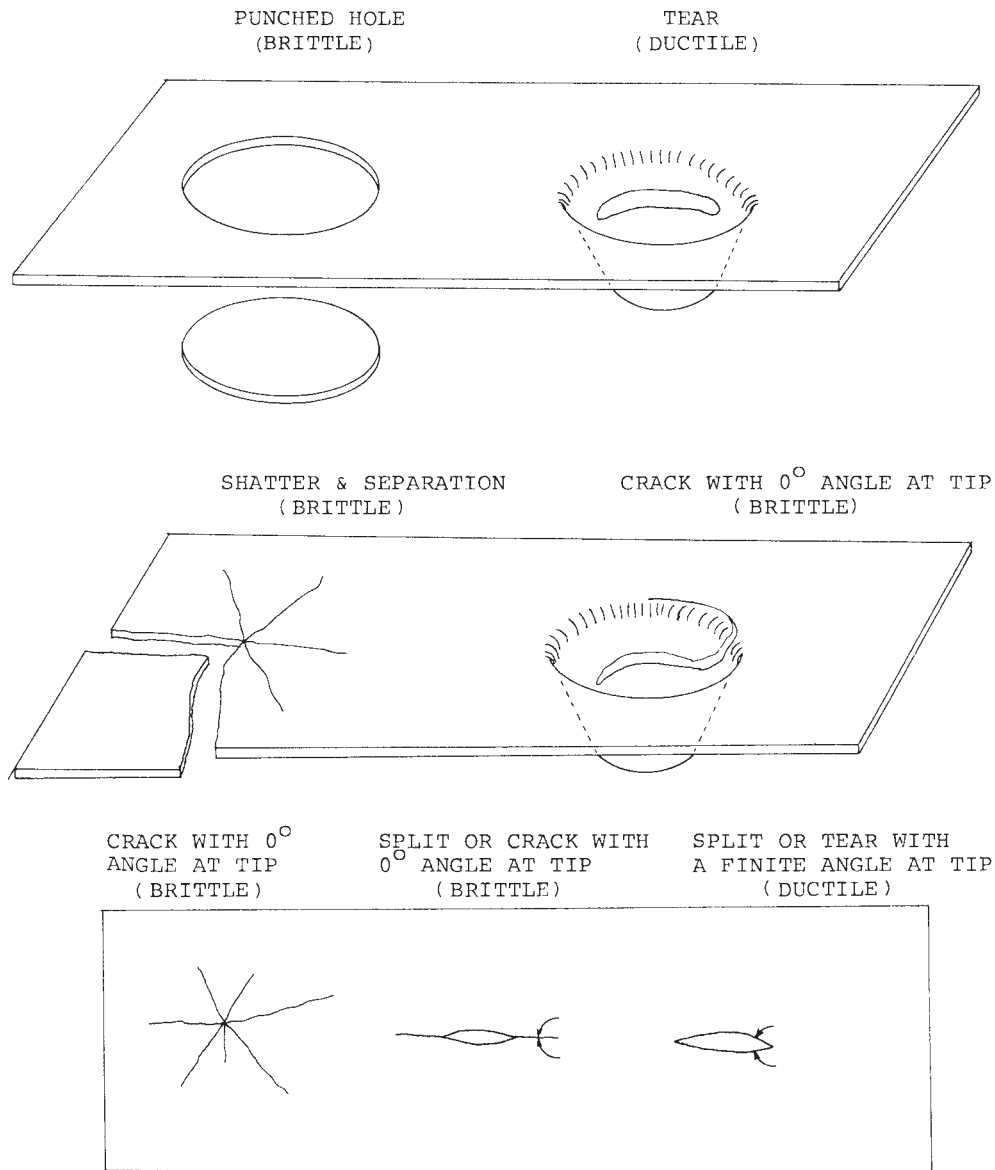

FIG. 1 Types of Failures of the Specimen

3.2.8 *normalized mean brittle failure energy (normalized mean energy of ductile-to-brittle transition)*, (Procedure B)—the mean brittle failure energy per unit (average) specimen thickness.

3.2.9 *outlier*—an observation that appears to deviate markedly from other members of the sample in which it occurs.

#### 4. Summary of Test Method

4.1 The building product profile is cut apart, if necessary, to obtain a flat specimen at least 0.75 in. (19 mm) wide.

4.2 Procedure A establishes the height from which a standard falling 8-lb (3.6-kg) weight will cause 50 % of the specimens to fail.

4.3 Procedure B establishes the height from which a standard falling 8-lb (3.6-kg) weight will cause 50 % of the specimens to fail in a brittle mode.

4.4 Both procedures employ either of two configurations of impactor heads resting on the specimen. The specimen lays on

a stand that has a 0.64-in. (16.3-mm) hole. The falling weight impacts on the impactor head tending to drive it through the specimen into the hole of the stand.

4.5 The technique used to find 50 % failure level in both procedures is commonly called the Bruceton Staircase Method or Up-and-Down Method. Testing is concentrated near the mean, reducing the number of specimens required to obtain a reasonably precise estimate.

#### 5. Significance and Use

5.1 The impact strength values obtained on the flat sections of a building product profile are relevant only to the flat section that has been tested and these values do not necessarily indicate the impact resistance of the whole product, which is affected by the configuration of the profile (that is, corners, ribs, etc).

5.2 Constant weight and variable height, employed in these test methods, allow the velocity of impact to vary and, therefore, by Procedure B, can determine the energy of

ductile-to-brittle transition, which cannot be determined if a variable weight is dropped from a constant height.

5.3 These test procedures have been found to be useful elements in rigid poly(vinyl chloride) (PVC) building product characterization. Compound qualification, finished product quality control, environmental and weatherability research and development studies, and fabrication tolerance prediction constitute useful applications.

5.4 Choice of the specific impactor head configuration used is related to a variety of product attributes, such as specimen thickness and product toughness as well as abstract factors, such as the anticipated mode of failure in a specific application. The geometric uniqueness of the impactor head configurations prevents any comparison or correlation of testing results on samples tested with differing impactor head configurations. In general, the conical impactor, C.125, is useful to ensure failure thicker specimens where the H.25 impactor caused no failure.

NOTE 2—Equivalent surface conditions are more likely to occur when specimens are prepared by compression molding or extrusion than by injection molding.

5.5 When comparing different samples tested with the same impactor head configuration, impact resistance can be normalized for average specimen thickness over a reasonably broad range (for example, 1 to 3 mm).<sup>7</sup> However, this should only be done when the surface conditions listed in 6.1 are essentially equivalent.

<sup>7</sup> O.R. Weaver, "Using Attributes to Measure a Continuous Variable in Impact Testing Plastic Bottles," Materials Research & Standards, MR & S, Vol. 6, No. 6, June, 1996, pp. 285-291.

## 6. Interferences

6.1 The results obtained are greatly influenced by the quality of the test specimens. Cracks usually start at the surface in tension; the surface opposite the one that is struck by the impactor head. The composition of this surface layer and the degree of orientation introduced during the formation of the specimen are very important variables. Flaws in this surface will also affect results. Because of these factors, sometimes additional information about the sample is achieved by testing the sample from a variety of locations in a product or testing from both sides of a flat section.

## 7. Apparatus

7.1 *Testing Machine*— The apparatus shall be constructed essentially as shown in Fig. 2 and Fig. 3 and shall consist of the following: suitable base to withstand the impact shock; steel-rod impact weight weighing  $8 \pm 0.2$  lb ( $3.6 \pm 0.1$  kg); hardened steel impactors as specified in 7.1.1; a slotted guide tube 40 in. (1.0 m) in length in which the impact weights slide, having an internal diameter sufficient so that friction does not reduce the weight velocity, and having graduations in inch-pound (newton-metre) increments, or multiples thereof. A bracket is used to hold the tube in a vertical position by attaching it to the base and also to hold the hand knob, which is a pivot-arm alignment for the impactor, about 2 in. (50 mm) under the tube. The top edge of the opening in the specimen support plate should be rounded to a 0.031-in. (0.8-mm) radius. Fig. 3 shows the specimen support configuration for this test.

### 7.1.1 Impactor Configurations:

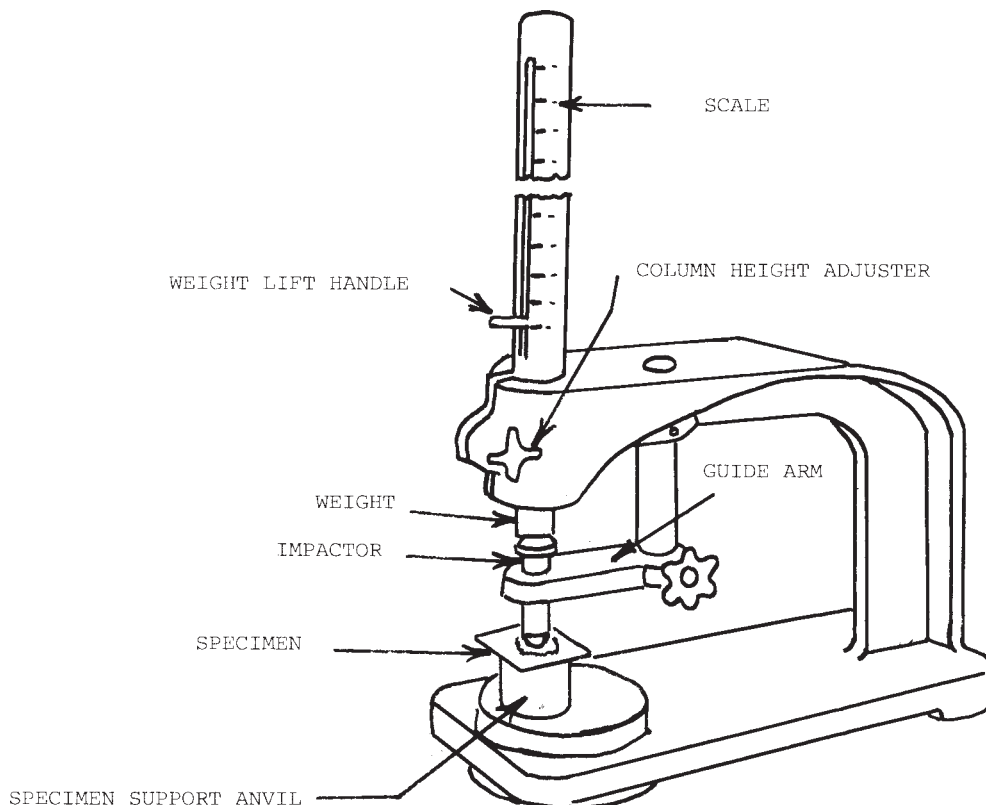

FIG. 2 Impact Tester

Depth of Penetration  
when fully seated  
shall be  $0.48 \pm 0.04$  in.  
( $12.2 \pm 0.1$  mm)

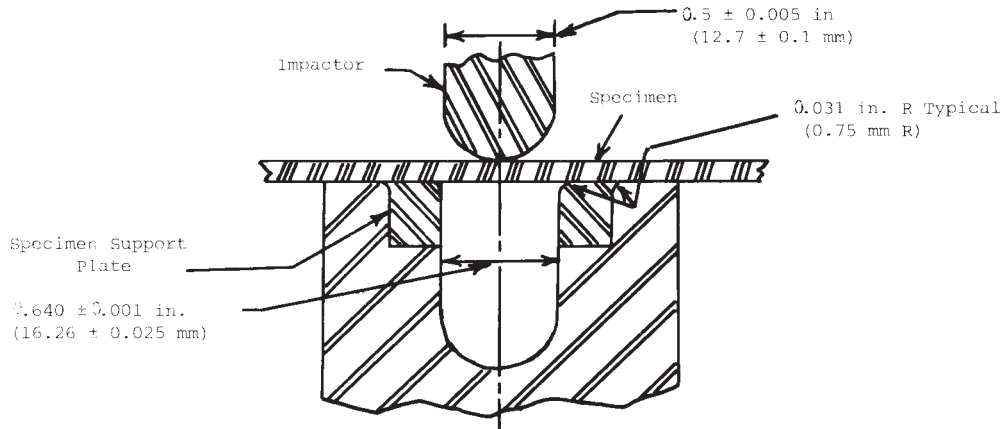

FIG. 3 Impactor Head Configuration H.25 Specimen Support Detail

7.1.1.1 *Impactor C.125* shall be constructed, as is shown in Fig. 4, of tough, hardened (Rockwell C 50-55), scratch resistant steel. It should have a conical ( $40^\circ$ ) configuration and 0.125-in. (3.18-mm) radius hemispherical tip.

7.1.1.2 *Impactor H.25* shall be constructed, as is shown in Fig. 3, of tough, hardened (Rockwell C 50-55) scratch resistant steel. It should have a 0.25-in. (6.35-mm) radius hemispherical tip (see Fig. 3 and Fig. 4).

7.1.1.3 The surface of the impactor head shall be polished free of nicks, scratches, or other surface irregularities.

7.2 *Supporting Base*—In order to minimize the energy absorption, compression, and deflection of the support the tester shall be firmly fixed to a dense, solid, block or base.

7.2.1 The main body of said block or base shall have maximum dimensions of 16 in. (h)  $\times$  30 in. (w)  $\times$  30 in. (d) and shall have a minimum weight of 400 lbs. This block shall be placed at a height that facilitates equipment usage. It is not necessary to bolt blocks or bases of this weight to the floor.

NOTE 3—The required block weight and dimensions conform to commercially available butcher block type tables.

7.2.2 Alternative supporting bases or those lighter than 400 lbs should be bolted to a concrete floor. Mean failure energy comparisons shall be made between these alternative supports and one where the tester is bolted directly to the concrete floor. If mean failure energy differences between the concrete floor and the alternative support are found statistically nonsignificant, use of the lighter support shall be allowed.

7.2.3 Use of rubber mats either under the tester or the supporting base is prohibited.

7.3 *Micrometer*, for measurement of specimen thickness. It should be accurate to 1 % of the average thickness of specimens used. See Test Methods D 374 for suitable micrometers.

## 8. Safety Precautions

8.1 Shielding devices shall be provided to protect personnel.

8.2 A tube can contain the impactor head if it rebounds after striking a specimen, or the impactor head may be drilled for a

cotterpin to prevent rebound. The cotterpin must be located well above the penetration depth of the impactor head.

## 9. Sampling

9.1 Select samples in accordance with Practice D 1898. The samples shall be representative of the lot under study.

## 10. Test Specimen

10.1 Flat test specimens at least 0.75-in. (19-mm) wide can be tested. The specimens shall be free of obvious imperfections unless they constitute variables under study.

10.2 When the approximate mean failure height for a given sample is known, 20 specimens usually yield sufficiently precise results. If the mean failure height cannot be approximated, six or more specimens should be used to determine the appropriate starting point of the test.

NOTE 4—Specimen quantity, as small as five, often yields sufficiently reliable estimates of the mean failure height. However, the estimated standard deviation will be relatively large.<sup>8</sup>

## 11. Conditioning

11.1 Unless otherwise specified, condition the test specimens at  $73.4 \pm 3.6^\circ\text{F}$  ( $23 \pm 2^\circ\text{C}$ ) and  $50 \pm 5$  % relative humidity for not less than 40 h prior to test in accordance with Procedure A of Methods D 618. In cases of disagreement, the tolerance shall be  $\pm 1.8^\circ\text{F}$  ( $\pm 1^\circ\text{C}$ ) and  $\pm 2$  % relative humidity.

11.2 *Quality Control Tests*—Condition the test specimens at  $73.4 \pm 3.6^\circ\text{F}$  ( $23 \pm 2^\circ\text{C}$ ) for 4 h in air.

## 12. Procedure

12.1 *Procedure A:*

12.1.1 Measure and record the thickness of each specimen at the anticipated area of impact. Average the values for all

<sup>8</sup> Brownless, K. A., Hodges J. L., Jr., and Rosenblatt, Murray, "The Up-and-Down Method with Small Samples," *American Statistical Association Journal*, JSTNA, Vol. 48, 1953, pp. 262-277.

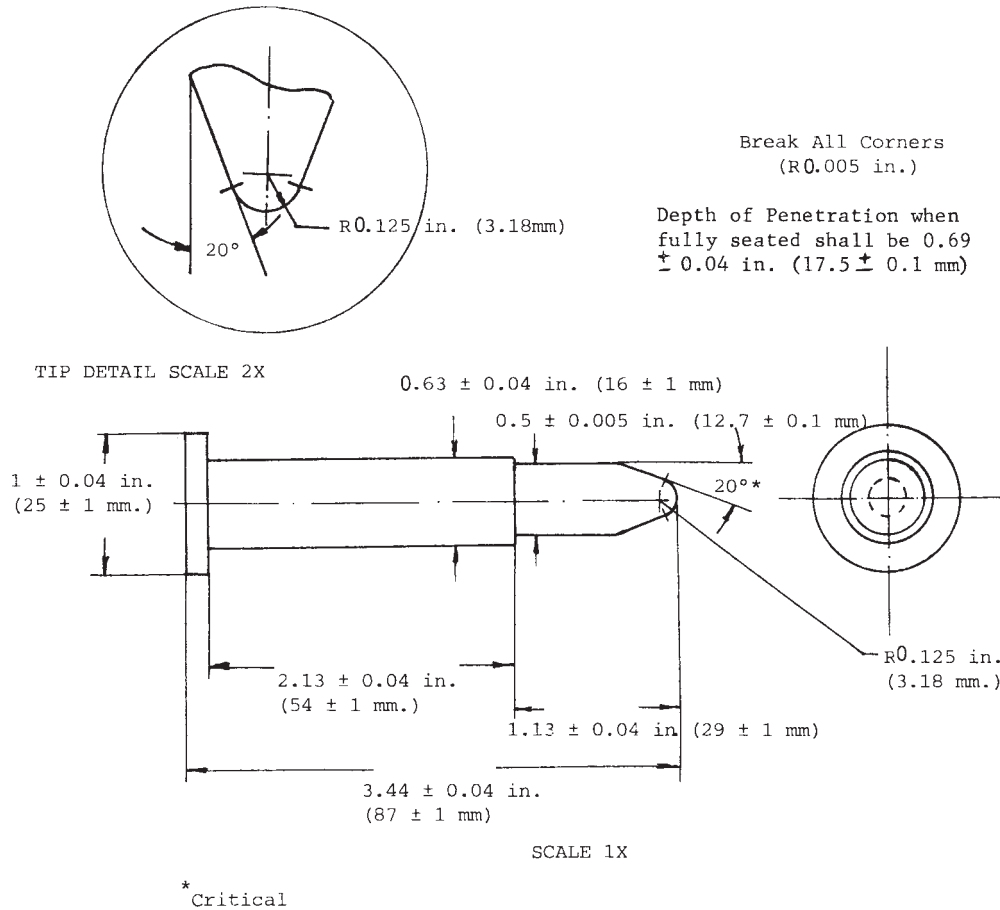

FIG. 4 Impactor Head Configuration C.125

specimens in a sample and use this average thickness in calculating normalized mean failure energy.

NOTE 5—When using a large specimen, such as PVC sliding, measure the thickness at five points uniformly across the width of the specimen. Use the average of these five values as the average thickness to calculate the normalized mean failure energy.

12.1.2 Choose a specimen at random from the sample. Determine the order of testing by using a set of random numbers.

12.1.3 Select the proper impactor-head configuration (C.125 or H.25) specified for the test and install on the apparatus. Adjust the guide arm so that each impactor head is visually centered and achieves the proper depth of penetration. Depth of penetration is the distance the impactor head protrudes into the support plate when properly seated. For the H.25 tup this shall be 0.48 in ± 0.04 in. (1.22 cm ± 0.10 cm) (Fig. 3) and 0.69 in. ± 0.04 in. (1.75 cm ± 0.10 cm) for the C.125 tup (Fig. 4).

NOTE 6—Centering of Tup- Periodic visual inspection during testing ensures tup is centered.

12.1.4 After raising the weight and impactor foot, place the specimen between the mandrel and the anvil making sure that it lies flat and covers the anvil. The clamping force, when clamping is used, shall be sufficient to prevent motion of the specimen.

12.1.5 Place the impactor foot so that it rests on the specimen.

12.1.6 Raise the weight in the tube to the approximate failure energy value for the specific sample and release it so that the weight drops on the impactor. If the approximate failure energy value for the sample is unknown, run about six impact tests at varying energy levels to bracket the approximate failure energy level before initiating the test series of impacts.

12.1.7 Remove the specimen and examine it to determine whether it has failed. See 3.2.1 for criteria of failure.

12.1.8 If the first impact of the specimen results in failure, decrease the drop height one increment. If the first impact of the specimen does not cause failure, increase the drop height one increment. Then test a second specimen or target point on the specimen.

12.1.9 In this manner, select the impact height for each successive test from the results observed with the specimen just previously tested. The same target point on a specimen shall not be tested more than once.

12.1.10 For best results, the height increment used should be approximately equivalent to  $s$ , the estimated standard deviation of the test for that sample. An increment from 0.5 to 2 times  $s$  is satisfactory (see 13.6).

12.1.11 Keep a running plot of the data. Use one symbol, such as "X", to indicate a failure and a different symbol, such as "O", to indicate a nonfailure at each height level.



12.1.12 For any specimen that gives a break behavior that appears to be an outlier, the conditions of that impact shall be examined. The specimen may be discarded only if a unique cause for the anomaly can be found, such as an internal flaw visible in the broken specimen. Note that break behavior may vary widely within a set of specimens. Data from specimens which show atypical behavior shall not be discarded simply on the basis of such behavior. Refer to Practice E 178 for detailed information on how outliers shall be handled.

12.2 Procedure B:

12.2.1 Test the specimen in the same way as described in Procedure A (12.1.1-12.1.9).

12.2.2 If brittle failure is observed (Fig. 1) at the mean failure height, the mean brittle failure height and mean brittle failure energy are the same as mean failure height and mean failure energy for the specimen.

12.2.3 If ductile breaks are observed (Fig. 1), continue the test by increasing the height by increments, as described in Procedure A, until a brittle failure occurs.

12.2.4 Use one symbol, such as “D”, to indicate ductile break and a different symbol, such as “B”, to indicate brittle failure at each height level.

13. Calculation

13.1 Mean Failure Height (Procedure A)—Calculate the mean failure height from the test data obtained as follows:

$$h = h_o + d_h(A/N \pm 0.5) \tag{1}$$

where:

- $h$  = mean failure height, in. (mm),
- $d_h$  = increment of weight height, in. (mm),
- $N$  = total number of failures or nonfailures, whichever is smaller. For ease of notation, call whichever is used “events,”
- $h_o$  = lowest height at which an event occurred, in. (mm),
- $A = \sum_{i=0}^k in_i$ ,
- $i = 0, 1, 2 \dots k$  (counting index, starts at  $h_o$ ),
- $n_i$  = number of events that occurred at  $h_i$ , and
- $h_i = h_o + id_h$

In calculating  $h$ , the negative sign is used when the events are failures. The positive sign is used when the events are nonfailures. See the example in Fig. 5.

13.2 Mean Brittle Failure Height (Procedure B)—Calculate the mean brittle failure height using the same formula as in Procedure A. Designations of  $h$  and  $N$  are different, as follows:

- $h$  = mean brittle failure height in. (cm), and
- $N$  = total number of brittle failures or ductile breaks, whichever is smaller.

In calculating  $h$ , the negative sign is used within the parentheses when the events are brittle failures. The positive sign is used when the events are ductile breaks.

13.3 Mean Failure Energy (Procedure A)—Compute the mean failure energy as follows:

$$MFE = h \times w \tag{2}$$

where:

HEIGHT cm	OUTCOME OF TEST																										
	X = FAILURE										O = NON FAILURE					⊕ = DUCTILE					⊗ = BRITTLE						
	1	2	3	4	5	6	7	8	9	10	11	12	13	14	15	16	17	18	19	20	21	22	23	24	25		
50																											
45																											
40																											
35																						⊗	X				
30																					⊕	X		⊕	X	⊕	X
25							⊕	X																		⊕	X
20						O		⊕	X	⊕	X			⊕	X		⊕	X									
15		⊕	X		O					⊕	X		O			⊕	X		⊕	X		O					
10	O		O								O							O		O							

MEAN FAILURE HEIGHT						
HEIGHT cm	$N_x$	$N_o$	$i$	$in_i$	$iN_1$	$i^2N_1$
25	1	0	2	2	2	4
20	4	1	1	4	4	4
15	4	5	0	4	0	0
10	0	5				
TOTALS	9	11		9	6	8
	$N_x$	$N_o$		(N)	(A)	(B)

$h_o = 15, N = N_x = 9, d = 5 \text{ cm}$   
 $h = h_o + d \left( \frac{A}{N} - 0.5 \right)$   
 $h = 15 + 5 \left( \frac{6}{9} - 0.5 \right)$   
 $h = 15.80 \text{ cm}$   
 $s = 1.620d \left[ \frac{(NB - A^2)}{N^2} + 0.029 \right]$   
 $s = 1.620(5) \left[ \frac{(9 \cdot 8 - 6^2)}{9^2} + 0.029 \right]$   
 $s = 3.8 \text{ cm}$

MEAN BRITTLE FAILURE HEIGHT						
HEIGHT cm	$n$	$n$	$i$	$i$	$iN_1$	$i^2N_1$
35	0	1	1	1	1	1
30	1	2	0	2	0	0
25	2	0				
20	4	0				
TOTALS	7	3		3	1	1
	$(N_x)$	$(N_B)$		(N)	(A)	(B)

$h_o = 30, N = N_B = 3, d = 5 \text{ cm}$   
 $h = h_o + d \left( \frac{A}{N} - 0.5 \right)$   
 $h = 30 + 5 \left( \frac{1}{3} - 0.5 \right)$   
 $h = 28.65 \text{ cm}$   
 $s = 1.620d \left[ \frac{(NB - A^2)}{N^2} + 0.029 \right]$   
 $s = 1.620(5) \left[ \frac{(3 \cdot 1 - 1^2)}{3^2} + 0.029 \right]$   
 $s = 5.6 \text{ cm}$

FIG. 5 Sample Calculations

*MFE* = mean failure energy, in.·lbf (J),  
*h* = mean failure height, in. (cm), and  
*w* = weight, 8 lb (3.6 kg).

13.4 *Mean Brittle Failure Energy* (Procedure B)—Compute the mean brittle failure energy as follows:

$$MBFE = h \times w \quad (3)$$

where:

MBFE = mean brittle failure energy, in.·lbf (J),  
*h* = mean brittle failure height, in. (cm), and  
*w* = weight, 8 lb (3.6 kg).

13.5 Normalized mean failure energy (Procedure A) and normalized mean brittle failure energy (Procedure B) are calculated by dividing the mean energy by the average thickness.

13.6 *Estimated Standard Deviation*—Calculate the estimated standard deviation from the test data as follows:

$$s = 1.620d\sqrt{[(NB - A^2)/N^2] + 0.029} \quad (4)$$

$$B = \sum_{i=0}^k$$

## 14. Report

14.1 The report shall include the following:

14.1.1 Complete identification of the sample tested, manufacturer's code, form, principle dimensions, and previous history.

14.1.2 Procedure used, either A or B, or both.

14.1.3 Impactor head configuration used, either C.125 or H.25, or both.

14.1.4 Average thickness of specimen tested.

14.1.5 Number of test specimens (target points) employed to determine the mean failure height.

14.1.6 Mean failure energy (Procedure A) or mean brittle failure energy (Procedure B), or both.

14.1.7 Estimated standard deviation.

14.1.8 Normalized mean energies, when required.

14.1.9 Any departures from the specified test procedures.

## 15. Precision and Bias

15.1 *Precision*—An interlaboratory study with six laboratories was conducted in which thick flat sections from various rigid poly(vinyl chloride) (PVC) extruded profiles were tested with impactor-head configuration C.125.

15.1.1 The average within-laboratory and between-laboratory coefficients of variation for Procedure A and for Procedure B were as follows:

Procedure	Average <i>V</i>	
	Within-laboratory	Between-laboratory
A	7.5	18.2
B	6.4	21.0

where:

$$V (\text{Procedure A}) = 100 S_{MFE\text{average}}$$

$$V (\text{Procedure B}) = 100 S_{MBFE\text{average}}$$

15.1.2 An additional study using impactor configuration H.25 with Procedure A to test PVC siding as a thickness of 0.040 in. (1 mm) is presently underway in the SPI Vinyl Siding Institute.

15.2 *Bias*—No statement of bias can be provided because of the lack of a referee method for impact behavior of plastic which can provide a “true” or reference value.

## 16. Keywords

16.1 brittle failure energy; building products; failure energy; falling weight; impact test

## SUMMARY OF CHANGES

Committee D20 has identified the location of selected changes to this standard since the last issue (D 4226–99) that may impact the use of this standard.

(1) Deletion of footnote 8, Reference to apparatus manufacturers.

(2) Modified 12.1.3, added depth of penetration language.

(3) Added Note 6.

*ASTM International takes no position respecting the validity of any patent rights asserted in connection with any item mentioned in this standard. Users of this standard are expressly advised that determination of the validity of any such patent rights, and the risk of infringement of such rights, are entirely their own responsibility.*

*This standard is subject to revision at any time by the responsible technical committee and must be reviewed every five years and if not revised, either reapproved or withdrawn. Your comments are invited either for revision of this standard or for additional standards and should be addressed to ASTM International Headquarters. Your comments will receive careful consideration at a meeting of the responsible technical committee, which you may attend. If you feel that your comments have not received a fair hearing you should make your views known to the ASTM Committee on Standards, at the address shown below.*

*This standard is copyrighted by ASTM International, 100 Barr Harbor Drive, PO Box C700, West Conshohocken, PA 19428-2959, United States. Individual reprints (single or multiple copies) of this standard may be obtained by contacting ASTM at the above address or at 610-832-9585 (phone), 610-832-9555 (fax), or service@astm.org (e-mail); or through the ASTM website (www.astm.org).*