



Standard Test Method for Purgeable Organic Compounds in Water Using Headspace Sampling¹

This standard is issued under the fixed designation D 3871; the number immediately following the designation indicates the year of original adoption or, in the case of revision, the year of last revision. A number in parentheses indicates the year of last reapproval. A superscript epsilon (ϵ) indicates an editorial change since the last revision or reapproval.

1. Scope

1.1 This test method covers the determination of most purgeable organic compounds that boil below 200°C and are less than 2 % soluble in water. It covers the low $\mu\text{g/L}$ to low mg/L concentration range (see Section 15 and Appendix X1).

1.2 This test method was developed for the analysis of drinking water. It is also applicable to many environmental and waste waters when validation, consisting of recovering known concentrations of compounds of interest added to representative matrices, is included.

1.3 Volatile organic compounds in water at concentrations above 1000 $\mu\text{g/L}$ may be determined by direct aqueous injection in accordance with Practice D 2908.

1.4 It is the user's responsibility to assure the validity of the test method for untested matrices.

1.5 *This standard does not purport to address all of the safety concerns, if any, associated with its use. It is the responsibility of the user of this standard to establish appropriate safety and health practices and determine the applicability of regulatory limitations prior to use.* Specific precautionary statements are given in 8.5.5.1.

2. Referenced Documents

2.1 ASTM Standards:

D 1129 Terminology Relating to Water²

D 1193 Specification for Reagent Water²

D 2908 Practice for Measuring Volatile Organic Matter in Water by Aqueous-Injection Gas Chromatography³

E 355 Practice for Gas Chromatography Terms and Relationships⁴

3. Terminology

3.1 *Definitions*—For definitions of terms used in this test method, refer to Terminology D 1129 and Practice E 355.

3.2 *Description of Term Specific to This Standard:*

¹ This test method is under the jurisdiction of ASTM Committee D19 on Water and is the direct responsibility of Subcommittee D19.06 on Methods for Analysis for Organic Substances in Water.

Current edition approved Jan. 10, 2003. Published January 2003. Originally approved in 1979. Last previous edition approved in 1995 as D3871 – 84 (1995) ^{ϵ 1}.

² *Annual Book of ASTM Standards*, Vol 11.01.

³ *Annual Book of ASTM Standards*, Vol 11.02.

⁴ *Annual Book of ASTM Standards*, Vol 14.02.

3.2.1 *purgeable organic*—any organic material that is removed from aqueous solution under the purging conditions described in this test method (10.1.1).

4. Summary of Test Method

4.1 An inert gas is bubbled through the sample to purge volatile compounds from the aqueous phase. These compounds are then trapped in a column containing a suitable sorbent. After purging is complete, trapped components are thermally desorbed onto the head of a gas chromatographic column for separation and analysis. Measurement is accomplished with an appropriate detector.

5. Significance and Use

5.1 Purgeable organic compounds, including organohalides, have been identified as contaminants in raw and drinking water. These contaminants may be harmful to the environment and man. Dynamic headspace sampling is a generally applicable method for concentrating these components prior to gas chromatographic analysis (**1 to 5**).⁵ This test method can be used to quantitatively determine purgeable organic compounds in raw source water, drinking water, and treated effluent water.

6. Interferences

6.1 Purgeable compounds that coelute with components of interest and respond to the detector will interfere with the chromatographic measurement. Likelihood of interference may be decreased by using dissimilar columns or a more selective detector for the chromatographic step.

7. Apparatus

7.1 *Purging Device*—Commercial devices are available for this analysis. Either commercial apparatus or the equipment described below may be used for this analysis. Devices used shall be capable of meeting the precision and bias statements given in 15.1.

7.1.1 *Glass Purging Device* having a capacity of 5 mL is shown in Fig. A1.1. Construction details are given in Annex A1. A glass frit is installed at the base of the sample reservoir to allow finely divided gas bubbles to pass through the aqueous

⁵ The boldface numbers in parentheses refer to the references at the end of this test method.

sample while the sample is restrained above the frit. The sample reservoir is designed to provide maximum bubble contact time and efficient mixing.

7.1.2 Gaseous volumes above the sample reservoir are kept to a minimum to provide efficient transfer and yet large enough to allow sufficient space for foams to disperse. Inlet and exit ports are constructed from 6.4-mm (1/4-in.) outside diameter medium-wall tubing so that leak-free removable connections can be made using “finger-tight” compression fittings containing plastic ferrules. The optional foam trap is used to control occasional samples that foam excessively.

7.2 *Trap*—A short section of stainless steel or glass tubing is packed with a suitable sorbent. Traps should be conditioned before use (Section 11). While other trap designs and sorbent materials may be used (see Section 12), the trap and sorbent described here are recommended and were used to collect precision and bias data. If another trap design or sorbent material is used, these precision and bias statements should be verified. A suitable trap design is 150 mm long by 3.17-mm outside diameter (2.54-mm inside diameter). The front 100 mm is packed with 60 to 80 mesh 2,6-diphenyl-*p*-phenylene oxide followed by 50 mm of 35 to 60-mesh silica gel. One trap design is shown in Fig. A1.2, with details in Annex A1. The body assembly acts as a seal for the exit end of the trap. The modified stem assembly is used to seal the inlet end of the trap when it is not in use.

7.3 *Desorber* consists of a trap heater and an auxiliary carrier gas source to backflush the trap at elevated temperatures directly onto the gas-chromatographic column. Desorber 1 (Fig. A1.3 and Annex A1) is dedicated to one gas chromatograph, but Desorber 2 can be used as a universal desorber for many gas chromatographs with a septum-type liquid-inlet system.

7.3.1 *Desorber 1* is attached directly onto the gas-chromatograph liquid-inlet system after removing the septum nut, the septum, and the internal injector parts. The modified body assembly is screwed onto the inlet system using the PTFE gasket as a seal. A plug is attached to one of the stem assemblies.

7.3.1.1 The assembled parts, simply called “the plug,” are used to seal the desorber whenever the trap is removed to maintain the flow of carrier gas through the gas-chromatographic column.

7.3.1.2 The flow controller, PTFE tubing, and stem assembly are used to provide the trap-backflush flow. This entire assembly also provides gas flow to operate the purging device.

7.3.2 *Desorber 2* (Fig. A1.4 and Annex A1) may be attached to any gas chromatograph by piercing the gas-chromatographic liquid-inlet septum with the needle.

7.3.2.1 The desorber is assembled in accordance with Fig. A1.4 with internal volumes and dead-volume areas held to a minimum. The heat source is concentrated near the base of the desorber so that the internal seals of the body assembly do not become damaged by heat. The use of a detachable needle assembly from a microsyringe makes it easy to replace plugged or dulled needles.

7.3.2.2 The flow controller, PTFE tubing, and stem assembly are used to provide the trap-backflush flow. This entire assembly is also used to provide gas flow to operate the purging device.

7.4 *Gas Chromatograph* equipped with a suitable detector, such as flame ionization, electrolytic conductivity, microcoulometric (halide mode), flame photometric, electron capture, or mass spectrometer.

7.4.1 The gas chromatographic conditions described below are recommended and were used to obtain precision and bias data (Section 15). If other column conditions are used, the analyst must demonstrate that the precision and bias achieved are at least as good as that presented in Section 15.

7.4.2 *Column* is 2.4 m by 2.4-mm inside diameter stainless steel packed with a suitable packing. Glass or nickel columns may be required for certain applications. Helium carrier gas flow is 33 mL/min and a flame ionization detector is used.

7.4.3 *Chromatograph Oven* is held at room temperature during trap desorption, then rapidly heated to 60°C and held for 4 min. Finally, the temperature is programmed to 170°C at 8°C/min and held for 12 min or until all compounds have eluted.

7.5 *Sampling Vials*, glass, 45-mL, sealed with PTFE-faced septa.⁶ Vial caps must be open-top screw caps to prevent vial breakage. The vials, septa, and caps are washed with detergent and hot water and rinsed with tap water and organic free water. The vials and septa are then heated to 105°C for 1 h and allowed to cool to room temperature in a contaminant-free area. When cool, the vials are sealed with septa, PTFE side down, and screw capped. Aluminum foil disks may be placed between the septa and screw cap to help minimize contamination. Vials are maintained in this capped condition until just prior to filling with water.

7.6 *Glass Syringe*, 5-mL with two-way syringe valve and 150 to 200 mm, 20-gage syringe needle.

8. Reagents and Materials

8.1 *Purity of Reagents*—Reagent grade chemicals shall be used in all tests. Unless otherwise indicated, it is intended that all reagents shall conform to the specifications of the Committee on Analytical Reagents of the American Chemical Society.⁷ Other grades may be used, provided it is first ascertained that the reagent is of sufficiently high purity to permit its use without lessening the accuracy of the determination.

8.2 *Purity of Water*—Unless otherwise indicated, Specification D 1193, Type II, will be used in this test method. Analyze a 5-mL aliquot of this water as described in Section 12 before preparing standard solutions. If the blank sample produces interferences for the compounds of interest, purge it free of volatile contaminants with purge gas (8.9) before using.

⁶ Pierce No. 13075 Screw Cap System Vials and 12722 Tuf-Bond Discs, Pierce Chemical Co., Rockford, IL, have been found satisfactory for this application.

⁷ *Reagent Chemicals, American Chemical Society Specifications*, American Chemical Society, Washington, DC. For suggestions on the testing of reagents not listed by the American Chemical Society, see *Anal. Standards for Laboratory Chemicals*, BDH Ltd., Poole, Dorset, U.K., and the *United States Pharmacopeia and National Formulary*, U.S. Pharmaceutical Convention, Inc. (USPC), Rockville, MD.

8.3 *Dechlorinating Agent*—Granular sodium thiosulfate or ascorbic acid.

8.4 *Trap Packings*⁸—60/80 mesh chromatographic grade 2,6-diphenyl-*p*-phenylene oxide and 35 to 60 mesh silica gel.⁹ Other packings may be needed for specific determinations.

8.5 *Stock Solutions*—Prepare a stock solution (approximately 2 mg/mL) for each material being measured, as follows:

8.5.1 Fill a 10.0-mL ground glass-stoppered volumetric flask with approximately 9.8 mL of methyl alcohol.

8.5.2 Allow the flask to stand unstoppered about 10 min or until all alcohol wetted surfaces dry.

8.5.3 Weigh the unstoppered flask to the nearest 0.1 mg.

8.5.4 Using a 100- μ L syringe, immediately add 6 drops of one reference material to the flask, then reweigh. Be sure that the drops fall directly into the alcohol without contacting the neck of the flask.

8.5.5 Dilute to volume, stopper, then mix by inverting the flask several times.

8.5.5.1 **Warning**—Because the reference materials are likely to be toxic and volatile, prepare concentrated solutions in a hood. It is advisable to wear rubber gloves and use an approved respirator when handling volatile toxic materials.

8.5.6 Calculate the concentration in micrograms per milliliter from the net gain in weight.

8.5.7 Store the solutions at 4°C. Warm to room temperature before use.

NOTE 1—Standard solutions prepared in methyl alcohol are generally stable up to 4 weeks when stored under these conditions. Discard them after that time has elapsed.

8.6 *Working Standard* (approximately 100 μ g/mL)—Prepare a working standard containing each compound to be tested, as follows.

8.6.1 Fill a 100-mL volumetric flask approximately three fourths full of methanol or acetone.

8.6.2 Pipet 1 mL of the stock solution (8.5) of each compound of interest into the flask, using subsurface addition. Stopper the flask except when actually transferring solutions.

8.6.3 After adding standard stock solutions, dilute to the mark with solvent and mix thoroughly. Immediately transfer this solution to a clean vial (7.5) by filling to overflowing and sealing with a septum, PTFE side down, and screw cap.

8.7 *Quality Check Sample* (approximately 20 μ g/L)—Just prior to calibration, prepare a quality check sample by dosing 20.0 μ L of the working standard solution (8.6) into 100.0 mL of water.

8.8 *Internal Standard Dosing Solution*—From stock standard solutions prepared as in 8.5, add a volume to provide 1000 μ g of each standard to 45 mL of water contained in a 50-mL volumetric flask, dilute to volume, and mix. Prepare a fresh internal standard dosing solution daily. Dose the internal standard solution into every sample and reference standard

analyzed. It is up to the analyst to choose internal standard compounds appropriate to the analysis.

8.9 *Purge Gas—Nitrogen or Helium*—Take precautions to prevent organic materials that may be present in the purge gas or laboratory air from contaminating the sample. High-purity purge gases (99.99 %) are desirable. Lower quality gases may be used if impurities are removed, for example by molecular sieve or low-temperature cold traps, or both.

9. Sampling

9.1 If the water has been chlorinated, add 1 to 2 mg of dechlorinating agent to the sampling vial (7.5) before sampling. Whether chlorinated or not, fill the vial to overflowing so that a convex meniscus forms at the top. Place a septum, PTFE side down, carefully on the opening of the vial, displacing the excess water. If an aluminum foil disk is to be used, place it over the septum. Then seal the vial with the screw cap and invert to verify the seal by demonstrating the absence of air bubbles.

NOTE 2—The sample should be headspace-free at this time. A small bubble may form if the vial is stored more than a few hours. *Analyze the sample within a few hours if possible.* If storage is necessary, maintain the sample temperature at 0 to 4°C until analyzed. Retighten the screw cap after the sample is chilled. Storage over charcoal will minimize contamination. Data on compounds tested showed them to be stable for at least 15 days.

10. Calibration and Standardization

10.1 Calibrate the system by analyzing replicate aliquots of the quality check sample (8.7), to which 5 μ L of the internal standard dosing solution (8.8) have been added, as described in Section 12. Replicate analyses permit the analyst to determine precision for each component.

10.1.1 Quantitative purging of each component, although desirable, is not required for successful analyses using this procedure. However, purging must be sufficiently reproducible to permit correction for incomplete recovery within the desired overall accuracy.

10.1.2 For each component, the percent recovery is calculated by comparing the gas chromatographic peak area response of the purged and trapped sample to the corresponding response of the same quantity of component injected directly into the chromatograph.

NOTE 3—Either incomplete purging or breakthrough of the trap will result in nonquantitative recovery by this test method. If the former is suspected, analyze a fresh aliquot of the quality check sample (8.7) using a longer purge time or an elevated sample temperature. If this increases the recovery, continue increasing the purge time or sample temperature until a recovery that satisfies the precision and bias statement (15.1) is obtained. If increasing the purge time decreases the recovery, the retention volume of the trap may have been exceeded, and try a shorter purge time. It is up to the analyst to demonstrate that the purge time and temperature are adequate for the specific analysis. In general, maintain the sample temperature constant to within $\pm 2^\circ\text{C}$ throughout an experiment.

11. Conditioning Traps

11.1 Condition newly packed traps with one of the desorbents (7.3) at 200°C for 16 to 24 h with a carrier flow of 20 mL/min, venting into the atmosphere. Condition used traps just before use (same day) by placing them in a desorbent and

⁸ 60 to 80 mesh Carbowax C coated with 0.2 % Carbowax 1500 preceded by 0.3 m of 60 to 80 mesh Chromosorb W-H.P., coated with 3 % Carbowax 1500, available from Supelco, Inc., Supelco Park, Bellefonte, PA 16823, has been found satisfactory for this application.

⁹ Tenax GC, a registered trademark of Enka, N.V., The Netherlands, and Davidson Type 15 silica gel has been found satisfactory for this application.

heating at 180°C for 10 min while backflushing with nitrogen or helium carrier gas at 20 mL/min.

NOTE 4—Certain mechanical details in this section may have to be modified when using a commercial instrument. Consult the manufacturer's manual.

12. Procedure

12.1 The specific purge, trap, and analysis conditions described in this section were used to collect the precision and bias data (15.1). Other conditions, including purge volume and flow rate, trap dimensions and packing material, and chromatographic columns, temperatures and detectors may also be suitable. The analyst must demonstrate that the precision and bias achieved are at least as good as that presented in Section 15.

12.1.1 Prior to analysis, allow sample to come to room temperature.

12.1.2 Adjust the flow rate of the inert purge gas (nitrogen or helium) to 40 mL/min. Insert the trap vent into the exit end of the trap and remove the cap. Then attach the trap to the device exit with a compression fitting. Remove the plungers from two 5-mL syringes and attach a closed syringe valve to each. Open the sample bottle and carefully pour the sample into one of the syringe barrels until it overflows. Replace the syringe plunger and compress the sample. Invert the syringe, open the valve, and vent any residual air while adjusting the sample volume to 5.0 mL. Close the valve.

12.1.2.1 Fill the second syringe in an identical manner from the same sample as a reserve for duplicate analysis, if necessary.

12.1.3 Open the valve on the sample syringe, introduce 5.0 µL of the internal standard dosing solution (8.8) through the valve bore with a microsyringe, and close the valve. Attach the 150 to 200-mm needle to the syringe valve and inject the sample into the purging device. Purge the sample 12 min or longer, if necessary, as determined in 10.1. If excessive foaming is observed, the sample may be diluted or the flow rate decreased with a corresponding increase in the purge time.

12.1.4 Disconnect and remove the trap from the purging device. Remove the vent plug from the trap and seal the trap with a cap securely tightened.

12.1.5 While the sample is being purged, stabilize the gas chromatograph oven temperature at 30°C or below. Proceed to 12.1.9 if using Desorber 2 (7.3.2).

12.1.6 If using Desorber 1 (7.2.1), remove its plug and the cap from the sample trap. Insert the trap into the desorber and lock it into place. Lock the trap-backflush fitting into place on the trap exit. Backflush the trap for 4 min with an inert gas flow of 20 mL/min while heating desorber at 180 ± 5°C. Remove the trap backflush fitting and close the gas chromatograph oven lid.

12.1.7 Temperature program the chromatograph oven as in 7.4.3. While the sample is being chromatographed, flush the purging device with two 5-mL volumes of water. If this does not adequately remove all impurities, disconnect the purging device, wash with appropriate solvent, rinse well with water and dry in a 200°C oven for 1 h.

12.1.8 After the analysis is complete, remove the sample trap by inserting the trap vent into the trap exit fitting; remove the trap and reseal the chromatograph inlet system with the plug. Remove the trap vent and reseal the trap with a cap in accordance with 12.1.2. Proceed to Section 13.

12.1.9 When using desorber 2, insert the needle through the gas chromatograph septum. Insert the sample trap into the desorber and securely lock into place. Install the trap-backflush fitting on the sample trap exit. Backflush the trap with inert gas at 20 mL/min for 4 min while heating desorber at 180 ± 5°C. Withdraw the needle from the septum and close the chromatograph oven lid. Temperature program the chromatograph oven as in 7.4. Remove the trap and seal it with a cap. Flush the purging device as in 12.1.7.

13. Calculation

13.1 First, calculate the percent recoveries of the internal standard compounds added to the sample. If these agree within ±15 %, of the experimental recoveries determined in 10.1.2, proceed to 13.2. If the recoveries differ by more than 15 %, repeat the analysis using the reserve 5-mL sample aliquot (13.2). Use the results of the second analysis to calculate concentrations.

13.2 Calculate the concentration in µg/L for each component in the sample, C_{sa} , using the ratio of its chromatographic response to the response of the same component from analysis of quality check sample, C_{st} (8.7).

$$C_{sa} = \frac{A_{sa}}{A_{st}} \times C_{st}$$

where:

A_{sa} = area of sample, and

A_{st} = area of standard.

14. Report

14.1 Report results in micrograms per litre for each component without correcting for recovery of internal standard dosing compounds. The recoveries of the internal standards dosing compounds should also be reported.

15. Precision and Bias ¹⁰

15.1 Seven operators from four laboratories determined three concentration levels of chloroform, 1,2,3-trichloropropane and chlorobenzene on 3 days. Three operators from two laboratories determined three concentration levels of benzene and ethylbenzene on three days. Samples were prepared in tap water filtered through activated charcoal to remove trace organic components. Recoveries and precision are given in Table 1 and Table 2, Appendix X1, and Table X1.1, Table X1.2 and Table X1.3.

15.2 These data may not apply to waters of other matrices.

16. Keywords

16.1 drinking water; gas chromatography; purge and trap; volatile organic compounds

¹⁰ Supporting data are available from ASTM Headquarters. Request RR:D19-1057.

TABLE 1 Recovery of Organic Compounds from Water

Compound	Added Level, µg/L	Recovery, %
Chloroform	4.8	121
	20.0	118
	375	99
Benzene	2.5	111
	11.3	93
	238	83
1,2,3-Trichloropropane	4.3	98
	23.7	82
	450	95
Chlorobenzene	3.3	116
	12.5	106
	263	92
Ethylbenzene	2.8	104
	13.8	114
	200	84

TABLE 2 Precision of Test Method for Purgeable Organic Compounds from Water

Compound	Mean Recovery, µg/L	Precision, µg/L	
		S _t	S _o
Chloroform	5.79	1.91	1.95
	23.6	13.8	7.7
	370	97.6	23.7
Benzene	2.79	1.05	0.98
	10.7	7.49	3.1
	196	23.2	15.2
1,2,3-Trichloropropane	4.2	2.30	0.82
	19.4	5.81	2.16
	428	86.2	66.2
Chlorobenzene	3.82	2.19	1.03
	13.3	10.5	3.98
	241	30.6	15.4
Ethylbenzene	2.90	1.32	0.89
	15.7	8.71	3.37
	168	17.8	17.9

ANNEX

(Mandatory Information)

A1. LIST OF PARTS AND INSTRUCTIONS FOR ASSEMBLY OF PURGING DEVICE, TRAP, AND DESORBERS

A1.1 *Purging Device*—The purging device (Fig. A1.1) is constructed from glass tubing. The glass frit installed at the base of the sample reservoir allows finely divided gas bubbles to pass through the aqueous sample while containing the sample above the frit. The sample reservoir is designed to provide maximum bubble contact time and efficient turbulent mixing. Gaseous volumes above the sample reservoir are kept to a minimum to provide efficient transfer characteristics and yet allow sufficient space for most foams to disperse. Inlet and exit ports are constructed from 6-mm outside diameter medium wall tubing so that leak-free removable connections can be made using “finger-tight” compression fittings containing plastic ferrules. The optional foam trap is used to control occasional samples that foam excessively. The straight portion of the purging device outlet tubing and the foam trap inlet tubing should be about 20 mm long to facilitate attachment.

A1.1.1 *Parts for Purging Device:*

Borosilicate Glass Tubing, 6-mm outside diameter standard wall and 14-mm outside diameter standard wall.

Glass Frit, 10-mm medium porosity, sealed into straight tubing.¹¹

Gas Chromatographic Half-Hole Septum or Septum Plugs, 6-mm.

Syringe, 5 mL.

Syringe Valve.¹²

Syringe Needle, 170 mm by 20-gage

Stainless Steel Reducing Union, ¹³1/4 to 1/8 in., with PTFE or nylon ferrules to attach trap to purging device exit.

¹¹ Corning No. 416760 (Catalog No. 39570-10M) has been found satisfactory for this purpose.

¹² Hamilton Valve (1 FLI2 way) has been found satisfactory for this purpose.

¹³ Swagelok reducing union No. 400-6-2 with TFE-fluorocarbon or nylon ferrules has been found satisfactory for this purpose.

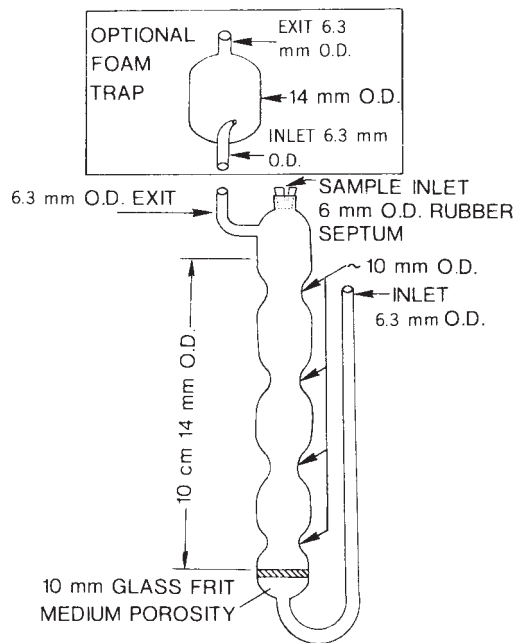

FIG. A1.1 Purging Device

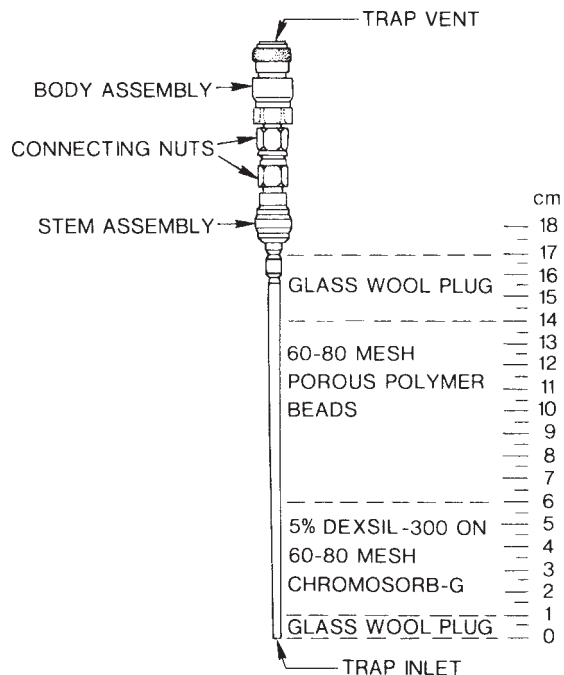

FIG. A1.2 Trap

A1.2 *Trap*—The trap is assembled and packed with the appropriate adsorptive material in accordance with Fig. A1.2. The body assembly acts as a seal for the exit end of the trap. The modified stem assembly is used to attach the trap to the desorption device. The cap is used to seal the inlet end of the trap when it is not in use (finger-tight).

A1.2.1 *Parts for Trap:*

Stainless Steel Tubing, 3.175-mm (0.125-in.) outside diameter by 2.67-mm (0.105-in.) inside diameter by 216 mm long (trap body)

Body Assembly Quick-Connect,¹⁴ the trap vent.

*Stem Assembly Quick-Connect*¹⁵ modified [drill through with a No. 30 (3.25-mm) drill to allow trap body to pass through entire fitting]

Cap, with PTFE or nylon ferrules

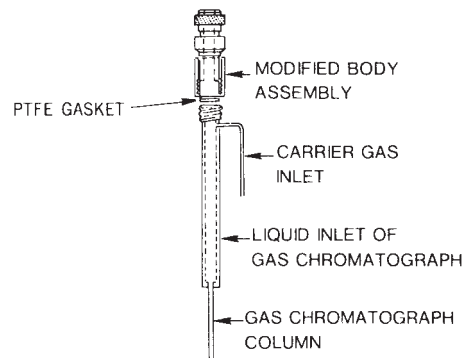
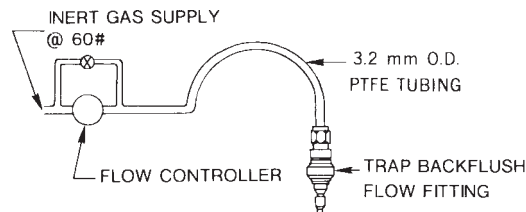

FIG. A1.3 Desorber 1

A1.3 *Desorbers*—Desorber 1 (Fig. A1.3) is attached directly onto the gas chromatograph liquid inlet system after removing the septum nut, the septum, and the internal injector parts. The modified body assembly is screwed onto the inlet system using the PTFE gasket as a seal. A plug¹⁶ is attached to one of the stem assemblies. These assembled parts called simply “the plug” are used to seal the desorber whenever the trap is removed to maintain the flow of carrier gas through the gas chromatographic column. The flow controller, PTFE tubing, and stem assembly are used to provide the trap backflush flow. This entire assembly is also used to provide gas flow to operate the purging device.

A1.3.1 *Parts for Desorber 1:*

Flow Controller, with No. 1 taper needle.¹⁷
PTFE Tubing, 3.175-mm (0.125-in.) outside diameter by 1.65-mm (0.065-in.) inside diameter by 1.5 m (5 ft) long
Stem Assembly, 3 each fittings¹⁵
*Body Assembly Fitting*¹⁸ modified with pipe threads drilled out using a 19.8-mm (²⁵/₃₂-in.) drill. The fitting is rethreaded using a ⁷/₁₆-20 bottoming tap. (The check ball and spring located within the body assembly are removed and discarded.)

¹⁴ Swagelok fitting No. QC4-B-200 has been found satisfactory for this purpose. Cajon Ultra-Torr fittings with Viton O-rings are also satisfactory quick-connect fittings

¹⁵ Swagelok fitting No. QC4-S-200 has been found satisfactory for this purpose.

¹⁶ Swagelok fitting No. 200-P has been found satisfactory for this purpose.

¹⁷ Brooks Model No. 8744 flow controller has been found satisfactory for this purpose.

¹⁸ Swagelok fitting No. QC4-B-2PF has been found satisfactory for this purpose.

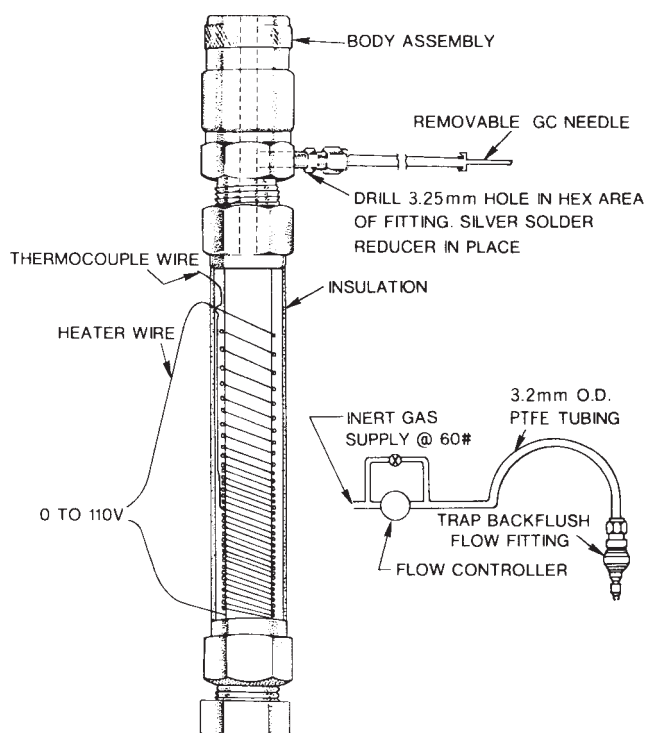

FIG. A1.4 Desorber 2

PTFE Gasket approximately 6.35 mm (1/4 in.) thick by 19.8-mm (25/32-in.) outside diameter by 3.97-mm (5/32-in.) inside diameter
*Plug.*¹⁷

A1.3.2 Desorber 2 (Fig. A1.4) may be attached to any gas chromatograph by piercing the gas chromatograph liquid inlet septum with the needle. The desorber is assembled in accordance with Fig. A1.4 with internal volumes and dead volume areas held to a minimum. The heat source is concentrated near the base of the desorber so that the internal seals of the body

assembly do not become damaged by heat. The use of a detachable needle assembly from a microsyringe makes it easy to replace plugged or dulled needles. The flow controller, PTFE tubing, and stem assembly are used to provide the trap backflush flow. This entire assembly is also used to provide gas flow to operate the purging device.

A1.3.2.1 *Parts for Desorber 2: Flow Controller*, with No. 1 taper needle.¹⁷

PTFE Tubing, 3.175-mm (0.125-in.) outside diameter by 1.65-mm (0.065-in.) inside diameter by 1.5 m (5 ft) long.

*Stem Assembly Quick-Connect.*¹⁵

*Body Assembly Quick-Connect,*¹⁹ modified (the check ball and spring are removed and discarded). A 3.25-mm hole is drilled through the hex area of the fitting and the reducing adaptor is silver soldered in place. Be sure to remove plastic seals located inside the body assembly fitting before silver soldering.

Stainless Steel Tubing, 6.35-mm (1/4-in.) outside diameter by 4.763-mm (3/16-in.) inside diameter by 130 mm long.

*Cap.*²⁰

Reducer.^{21, 22}

Thermocouple, compatible with pyrometer on gas chromatograph.

Heater Tape, useful up to 250°C.

Asbestos Tape.

Heat-Resistant Fiberglass Tape.

*Microsyringe Needle,*² side port 26 gage by 51 mm (2 in.) and detachable syringe needle assembly from microsyringe.

Variable Transformer, 0 to 140 V.

¹⁹ Swagelok fitting No. 316-QC4-B-400 as modified has been found satisfactory for this purpose.

²⁰ Swagelok cap No. 316-400-C has been found satisfactory for this purpose.

²¹ Swagelok fitting No. 316-100-R-2 has been found satisfactory for this purpose.

²² Precision sampling No. 913052 has been found satisfactory for this purpose.

APPENDIX

(Nonmandatory Information)

X1. SINGLE-OPERATOR PRECISION AND BIAS

X1.1 Table X1.1, Table X1.2, and Table X1.3, according to Bellar and Lichtenberg ((6)), demonstrate single-operator pre-

cision and bias for this test method for 25 compounds over a wide concentration range:

TABLE X1.1 Bias of Purge and Trap Method for Organohalides and Aromatic Hydrocarbons from Five Sample Sources

Compound Class	Sample Concentration, µg /L	Spike Concentration, µg/L	Number of Samples	Mean Recovery, %	Standard Deviation of Recovery
Organohalides ^A (15)	0.05 to 1560	0.1 to 500	42	101	13
Aromatic hydrocarbons ^B (10)	240 to 10 000	200 to 6000	10	92	10
All compounds (25)	0.05 to 1000	0.1 to 6000	52	99	12

^A Sample sources include: chemical manufacturing, pharmaceutical, landfill leachate, and contaminated ground water.

^B Wood products process water.

TABLE X1.2 Precision of the Purge and Trap Method for Organohalides ^A

Concentration Range, µg/L	0 to 0.99	1.0 to 9.9	10 to 19.9	20 to 99.9	>100
Number of occurrences	16	28	13	10	12
Average concentration, µg/L	0.40	4.6	14.4	50.7	565
Average relative standard deviation, ^B %	15.7	6.7	4.0	2.1	2.9
Range of relative standard deviation, %	0 to 38	0 to 28	1 to 10	0 to 10	0 to 6

^A Fifteen compounds measured in 12 samples representing chemical manufacturing effluent pharmaceutical process water and effluent, and contaminated ground water.

^B Average of three determinations.

TABLE X1.3 Precision of the Purge and Trap Method for Aromatic Hydrocarbons ^A

Concentration Range, µg/L	240 to 499	500 to 1000	>1000
Number of occurrences	8	3	8
Average concentration, µg/L	250	600	3200
Average relative standard deviation, ^B %	11	8.3	4.3
Range of relative standard deviation	6 to 17	4 to 11	1 to 16

^A Ten compounds measured in coke plant process water at various concentrations.

^B Average of three determinations.

REFERENCES

- (1) Bellar, T. A., and Lichtenberg, J. J., "The Determination of Volatile Organic Compounds at the µg/L Level in Water by Gas Chromatography," EPA-670/4-74-009, November 1974.
- (2) Bellar, T. A., Lichtenberg, J. J., and Kroner, R. C., "The Occurrence of Organohalides in Chlorinated Drinking Water," *Journal American Water Works Association*, Vol 66, 1974, p. 703.
- (3) Symons, J. M., et. al., "National Organics Reconnaissance Survey for Halogenated Organics," *Journal American Water Works Association*, Vol 67, 1975, p. 634.
- (4) Bellar, T. A., and Lichtenberg, J. J., "Determining Volatile Organics at Microgram-per-Litre Levels by Gas Chromatography," *Journal American Water Works Association*, Vol 66, 1974, p. 739.
- (5) "The Analysis of Trihalomethanes in Finished Waters by Purge and Trap," USEPA Environmental Monitoring and Support Laboratory, Cincinnati, OH, Sept. 9, 1977.
- (6) Bellar, T. A., and Lichtenberg, J. J., "Semiautomated Headspace Analysis of Drinking Waters and Industrial Waters for Purgeable Volatile Organic Compounds," *Symposium on Measurement of Organic Pollutants in Water and Waste Water, ASTM STP 686, ASTM*, 1979, p. 108.

ASTM International takes no position respecting the validity of any patent rights asserted in connection with any item mentioned in this standard. Users of this standard are expressly advised that determination of the validity of any such patent rights, and the risk of infringement of such rights, are entirely their own responsibility.

This standard is subject to revision at any time by the responsible technical committee and must be reviewed every five years and if not revised, either reapproved or withdrawn. Your comments are invited either for revision of this standard or for additional standards and should be addressed to ASTM International Headquarters. Your comments will receive careful consideration at a meeting of the responsible technical committee, which you may attend. If you feel that your comments have not received a fair hearing you should make your views known to the ASTM Committee on Standards, at the address shown below.

This standard is copyrighted by ASTM International, 100 Barr Harbor Drive, PO Box C700, West Conshohocken, PA 19428-2959, United States. Individual reprints (single or multiple copies) of this standard may be obtained by contacting ASTM at the above address or at 610-832-9585 (phone), 610-832-9555 (fax), or service@astm.org (e-mail); or through the ASTM website (www.astm.org).