



Standard Test Method for Dynamic Surface Tension by the Fast-Bubble Technique¹

This standard is issued under the fixed designation D 3825; the number immediately following the designation indicates the year of original adoption or, in the case of revision, the year of last revision. A number in parentheses indicates the year of last approval. A superscript epsilon (ϵ) indicates an editorial change since the last revision or reapproval.

1. Scope

1.1 This test method covers the determination of the specific free energy of a liquid-gas surface a short time after formation of the surface.

1.2 It is applicable to liquids with vapor pressures up to 30.0 kPa (225 torr) and kinematic viscosities up to 4.0 mm/s (4.0 cSt) at the test temperature. Higher viscosities have not yet been investigated.²

1.3 The values stated in SI units are to be regarded as the standard. The values given in parentheses are for information only.

1.4 *This standard does not purport to address all of the safety concerns, if any, associated with its use. It is the responsibility of the user of this standard to consult and establish appropriate safety and health practices and determine the applicability of regulatory limitations prior to use.* For specific precautionary statements, see 7.3, 7.4, and 7.5.

2. Referenced Documents

2.1 ASTM Standards:

D 1193 Specification for Reagent Water³

D 1331 Test Methods for Surface and Interfacial Tension of Solutions of Surface-Active Agents⁴

E 1 Specification for ASTM Thermometers⁵

3. Terminology

3.1 Definitions:

3.1.1 *surface tension* (γ)—the specific surface free energy of a liquid gas interface, millinewton per metre (ergs/cm²).

3.2 Definitions of Terms Specific to This Standard:

3.2.1 *bubble frequency* (S)—bubbling rate, s⁻¹.

3.2.2 *dead time* (t_o)—time required from start to completion of a bubble, ms.

3.2.3 *surface age* (t)—time required to start a new bubble, ms.

3.2.4 *dead time %*—fraction of a cycle ($t + t_o$) in the dead state, %.

3.2.5 *bubble pressure* (ΔP)—difference between maximum pressures for the wide capillary (P_1) and the narrow capillary (P_2), Pa.

3.3 Symbols:

γ = surface tension, millinewtons per metre (dynes/cm)

S = bubble frequency, s⁻¹

t_o = dead time, ms

t = surface age, ms

D = density, kg/m³

r = radius, mm

ΔP = difference between maximum pressures, Pa

P_1 = maximum pressure for the wide capillary, Pa

P_2 = maximum pressure for the narrow capillary, Pa

4. Summary of Test Method

4.1 The pressure required for bubble formation at a capillary tip immersed in the liquid is measured at gas flow rates that provide a series of bubble frequencies. The pressure and a calibration constant are used to calculate the dynamic surface tension at various surface ages.

5. Significance and Use

5.1 While this test method can be applied to pure liquids, it is especially designed for use with mixtures in which one or more components migrate to the surface.

5.2 Data of this type are needed for the design of equipment for processing mixed liquids, such as in distillation towers.

6. Apparatus

6.1 *Bubbler Unit*, water-jacketed, as shown in Fig. 1.

6.2 *Thermostat*, circulating water, to hold bubbler at specified temperature.

6.3 *Oven*, adjustable to 378 K (105°C), explosion-proof.

6.4 *Pressure Transducer*, diaphragm-resistive unbonded strain gage, time constant 25 ms or less, 0 to 2000 Pa, accuracy $\pm 2\%$.^{6,7}

¹ This test method is under the jurisdiction of ASTM Committee D02 on Petroleum Products and Lubricants and is the direct responsibility of Subcommittee D02.11 on Engineering Science of High Performance Fluids and Solids.

Current edition approved Oct. 26, 1990. Published December 1990.

² Kloubek, J., "Measurement of the Dynamic Surface Tension by the Maximum Bubble Pressure Method, III," *Journal of Colloid and Interface Science*, Vol. 41, October 1972, pp. 7–16.

³ *Annual Book of ASTM Standards*, Vol 11.01.

⁴ *Annual Book of ASTM Standards*, Vol 15.04.

⁵ *Annual Book of ASTM Standards*, Vol 14.03.

⁶ Razouk, R. "Surface Tension of Propellants," JPL Quarterly Technical Review Vol 2, 1972, pp. 123–133.

⁷ Razouk, R. and Walmsley, D., "Surface Tension Measurement by the Differential Maximum Bubble Pressure Method Using a Pressure Transducer," *Journal of Colloid and Interface Science*, Vol. 47, 1974, pp. 515–519.

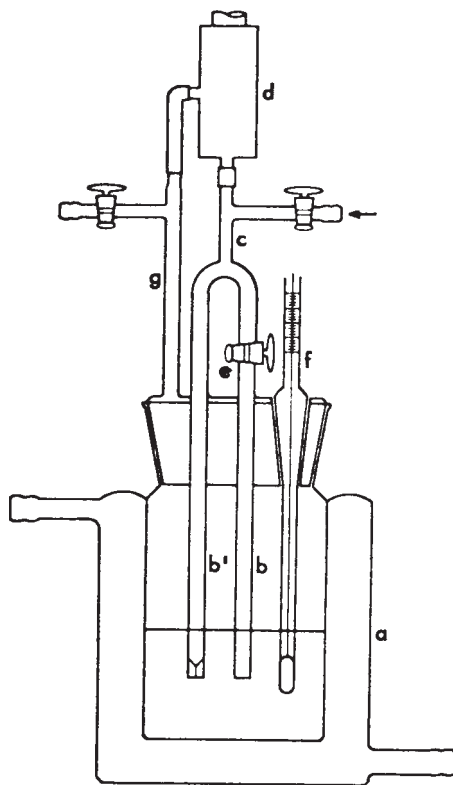

Tips of *b* and *b'* shall be cut squarely at exactly the same level, and finely ground (for example, 44 μm S;C (320 mesh S;C)).

FIG. 1 Bubbler Unit

6.5 *Bridge Power Supply*, for the strain gage.

6.6 *Oscilloscope*, capable of sweep times down to 0.020 s.

6.7 *Filtered (5- μm) Air Supply*, with pressure regulator capable of 0 to 724 kPa (0 to 105 psig) above ambient.

NOTE 1—Nitrogen shall be used in place of air if there is any problem of oxidizing the liquid.

6.8 *Thermometer*, appropriate range, conforming to Specification E 1.

7. Reagents and Materials

7.1 *Purity of Reagents*—Reagent grade chemicals shall be used in all tests. Unless otherwise indicated, it is intended that all reagents shall conform to the specification of the Committee on Analytical Reagents of the American Chemical Society,⁸ where such specifications are available. Other grades may be used, provided it is first ascertained that the reagent is of sufficiently high purity to permit its use without lessening the accuracy of the determination.

7.2 *Purity of Water*—Unless otherwise indicated, references to water shall be understood to mean reagent water conforming to Specification D 1193, Type III.

⁸ *Reagent Chemicals, American Chemical Society Specifications*, American Chemical Society, Washington, DC. For suggestions on the testing of reagents not listed by the American Chemical Society, see *Analar Standards for Laboratory Chemicals*, BDH Ltd., Poole, Dorset, U.K., and the *United States Pharmacopeia and National Formulary*, U.S. Pharmaceutical Convention, Inc. (USPC), Rockville, MD.

7.3 *Calibration Liquids*, reagent grade, covering a wide range of surface tension.

NOTE 2—Acetone, toluene, ethanol, and methanol have been found satisfactory for this purpose. **Acetone—Warning:** Extremely flammable. Vapors may cause flash fire. See Annex A1.1. **Toluene—Warning:** Flammable. Vapor harmful. See Annex A1.6. **Methanol—Warning:** Flammable. Vapor harmful. See Annex A1.5. **Ethanol—Warning:** Flammable. Denatured. See Annex A1.4.

7.4 *Cleaning Solution*, Chromic-sulfuric acid. **Warning:** Causes severe burns. A recognized carcinogen strong oxidizer, contact with organic material can cause fire. Hygroscopic. See Annex A1.2.

7.5 *Nitrogen*, of purity suitable to avoid reaction with test liquid and less than 100 ppm CO₂ with amines. **Warning:** Compressed gas under high pressure. See Annex A1.3.

8. Calibration and Standardization

8.1 Clean the bubbler with cleaning solution, and rinse with water. **Warning:** Causes severe burns. A recognized carcinogen. Strong oxidizer, contact with organic material may cause fire. Hygroscopic. See Annex A1.2. Condition by soaking in water for 48 h followed by a final rinse with water.

8.2 Set up the apparatus as shown in Fig. 2, and bring the thermostat to the desired temperature.

NOTE 3—If a test temperature is not specified, 298 \pm 0.1 K (25 \pm 0.1°C) is recommended.

8.3 Calibrate the transducer and the oscilloscope vertical scale against a suitable timer.

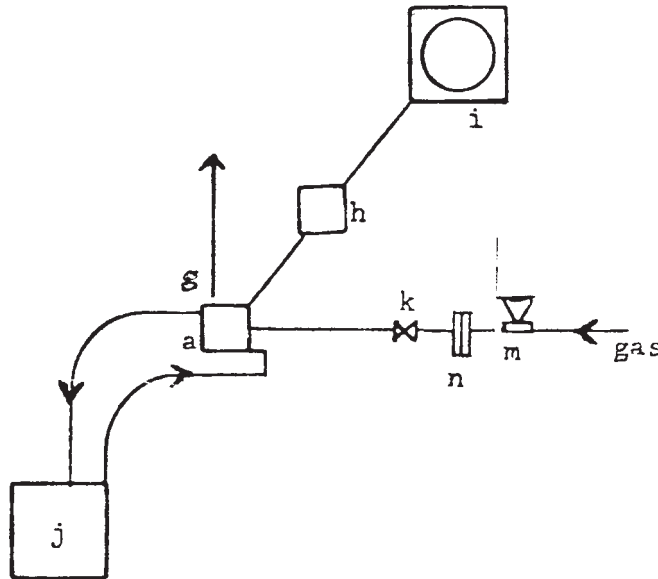

a—water jacket, b—wide capillary (inside diameter = 2.0 ± 0.1 mm), b'—narrow capillary (inside diameter = 0.11 ± 0.1 mm), c—inlet manifold, d—pressure transducer, e—stopcock, f—thermometer, g—vent line, h—bridge supply, i—oscilloscope, j—thermostat, k—needle valve, m—pressure regulator, n—filter, 5 μ m.
^A Do not use silicone grease on stopcocks or taper joint.

FIG. 2 Set-up of Apparatus^A

8.4 Measure the inner radius (r) of the wide capillary (b) by any suitable means to $\pm 5\%$.

8.5 Half-fill the bubbler with water; then connect it to thermostat and equilibrate it until the test temperature is reached.

8.6 Pass gas through the narrow capillary (b') at a rate to give $S = 0.5 \text{ s}^{-1}$ and record the pressure maximum as P_2 .

Warning: Compressed gas under high pressure. See Annex.

8.7 Open the stopcock (e) to the wide capillary and record the pressure as P_1 .

8.8 Empty the bubbler and dry in the oven.

8.9 Half-fill the bubbler with ethanol or methanol and repeat 8.5-8.8.

8.10 Repeat 8.9 with three other calibration liquids.

8.11 Calculate the calibration constant (A) for each of the five liquids by:

$$(A = \gamma/\Delta P (1 + 675 rD/\Delta P)) \quad (1)$$

Average the results.

8.11.1 In general, handbook values of D are satisfactory. However, the true value of γ for each supply of each calibration liquid must be known; if it is not available from other records, then test in accordance with Test Method D 1331 or equivalent.

9. Procedure

9.1 Clean the bubbler as in 8.1 and dry in the oven.

9.2 Half-fill the bubbler with the test liquid, connect to the thermostat and equilibrate.

9.3 Close the stopcock (e) on the wide capillary.

9.3.1 Pass dry gas through the narrow capillary as in 8.6 and record P_2 .

9.3.2 Synchronize the sweep circuit so that the pressure traces superimpose without drift, and record the sweep rate as S .

NOTE 4—To avoid synchronizing at $2S$ or $3S$, observe the bubbles visually.

9.3.3 Open the stopcock and record P_1 .

9.4 Close the stopcock and increase the flow rate by means of the needle valve (k), to give $S = 1.0 \text{ s}^{-1}$ and record S and P_2 . Open the stopcock and check P_1 .

9.5 Continue to double the gas flow rate, recording S and P_2 at each step, until evidence of dead time appears at the right-hand side of the display as idealized in Fig. 3. From then on it is necessary to record t_o or % dead time based on the horizontal scale of the display. Record P_1 at each step.

NOTE 5—For a similar apparatus, an empirical equation was developed:⁹

$$t_o = 31.9 - 0.25S \quad (2)$$

This can be used as a guide for observability of t_o , but not for calculation of results since unevaluated differences in dimensions exist.

9.6 Continue to double the gas flow rate, recording S , P_2 , t_o , and P_1 at each step, until regular bubbling breaks down, as shown by a sudden increase in P_2 .

NOTE 6—Breakdown depends on γ and viscosity, and on some equipment factors.² The highest rate obtained² was $S = 50$, with water plus surfactant. The lowest rate to show breakdown was $S = 20$, with the most

⁹ Austin, M., Bright, B. B. and Simpson, E. A., "The Measurement of the Dynamic Surface Tension of Manoxol OT Solutions for Freshly Formed Surfaces," *Journal of Colloid and Interface Science*, Vol 23, 1967, pp. 108-112.

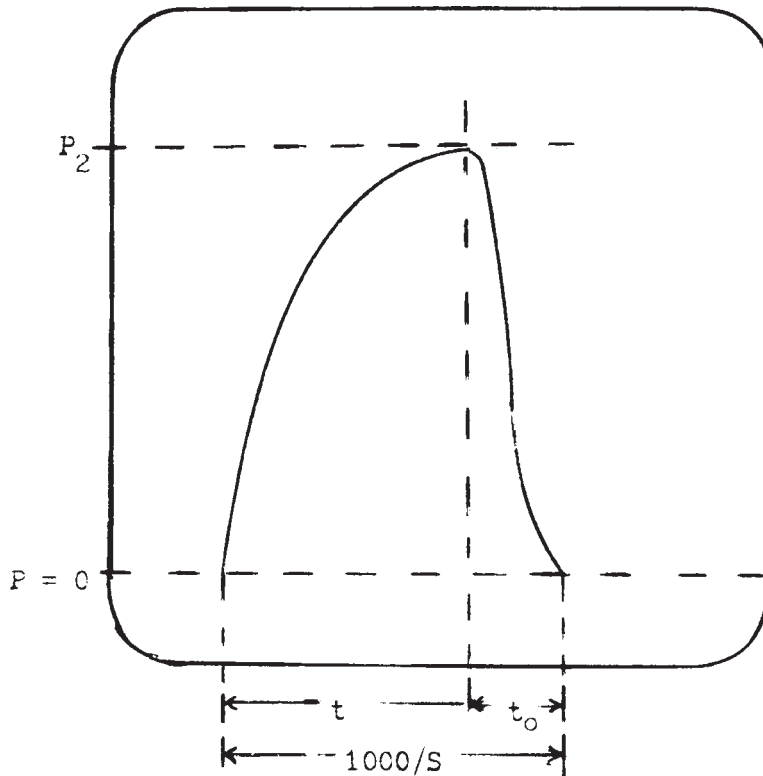

FIG. 3 Idealized Oscilloscope Display at About $S = 16$

viscous liquid (aniline with a viscosity of $4 \text{ mm}^2/\text{s}$ (4 cSt).

9.7 Reduce the gas flow rate to the initial value $S = 0.5$ within $\pm 1 \%$, and redetermine both P_2 and P_1 . If the difference ΔP is changed by more than $\pm 2 \%$ from that in 9.3, record that fact as evidence that the properties of the sample have been altered during the test.

10. Calculations

10.1 Calculate the surface age for each flow rate by the following equation:

$$t = (1000/S) (1 - \% t_d/100) \tag{3}$$

$$t = (1000/S) - t_o \tag{4}$$

10.2 Calculate the surface tension for each flow rate by the following equation:

$$(\gamma = A\Delta P(1 + 675rD/\Delta P)) \tag{5}$$

10.3 Plot the values of γ versus those of t , and interpolate for the value of γ at $t = 25 \text{ ms}$, or any other specified surface age.

11. Report

11.1 Report γ and t for all flow rates (usually 6 or 7).

11.2 Summary reports may consist of γ for $t = 2000 \text{ ms}$ as *static surface tension* and for $t = 25 \text{ ms}$, or other specified time, for *dynamic surface tension*.

11.3 If the ΔP measured in the check test 9.7 differs appreciably from that measured originally in 9.3, report that the liquid changed during the test by mN/m or ergs/cm^2 difference.

12. Precision and Bias

12.1 Committee D02 has no immediate plan at this time to develop precision and bias statements for this test method.

13. Keywords

13.1 dynamic surface tension; tension (tensile) properties/ tests; surface tension

(Mandatory Information)
A1. PRECAUTIONARY STATEMENTS
A1.1 Acetone

Warning: Extremely flammable. Vapors may cause flash fire.

Keep away from heat, sparks, and open flame.

Keep container closed.

Use with adequate ventilation.

Vapors may spread long distances and ignite explosively.

Avoid build-up of vapors and eliminate all sources of ignition, especially nonexplosion proof electrical apparatus and heaters.

Avoid prolonged breathing of vapor or spray mist.

Avoid contact with eyes and skin.

In case of spillage absorb and flush with large volumes of water.

In case of fire use water, dry chemical, CO₂, or foam.

A1.2 Chromic Acid (Cleaning Solution)

Warning: Causes severe burns. A recognized carcinogen.

Strong oxidizer—contact with other material can cause fire.

Hygroscopic.

Do not get in eyes, on skin, on clothing.

Avoid breathing vapor or mist.

Keep container closed.

Use with adequate ventilation.

Do not take internally.

Wash thoroughly after handling.

In case of spillage soak up with excess sodium carbonate and flush with plenty of water.

A1.3 Compressed Gases, Nitrogen

Warning: Compressed gas under high pressure. Gas reduces oxygen available for breathing.

Keep container closed.

Use with adequate ventilation.

Do not enter storage areas unless adequately ventilated.

Always use a pressure regulator. Release regulator tension before opening cylinder.

Do not transfer to cylinder other than one in which gas is received. Do not mix gases in cylinders.

Do not drop cylinder. Make sure cylinder is supported at all times.

Stand away from cylinder outlet when opening cylinder valve.

Keep cylinder out of sun and away from heat.

Keep cylinders from corrosive environment.

Do not use cylinder without label.

Do not use dented or damaged cylinders.

For technical use only. Do not use for inhalation purposes.

A1.4 Ethanol or Ethyl Alcohol

Warning: Flammable. Denatured cannot be made non-toxic.

Keep away from heat, sparks, and open flame.

Keep container closed.

Use with adequate ventilation.

Avoid prolonged breathing of vapor or spray mist.

Avoid contact with eyes and skin.

Do not take internally.

A1.5 Methanol (Methyl Alcohol)

Warning: Flammable. Vapor harmful.

Can be fatal or cause blindness if swallowed or inhaled.

Cannot be made nonpoisonous.

Keep away from heat, sparks, and open flame.

Keep container closed.

Avoid contact with eyes and skin.

Avoid breathing of vapor or spray mist.

Use with adequate ventilation.

Do not take internally.

A1.6 Toluene

Warning: Flammable. Vapor harmful.

Keep away from heat, sparks, and open flame.

Keep container closed.

Use with adequate ventilation.

Avoid breathing of vapor or spray mist.

Avoid prolonged or repeated contact with skin.

The American Society for Testing and Materials takes no position respecting the validity of any patent rights asserted in connection with any item mentioned in this standard. Users of this standard are expressly advised that determination of the validity of any such patent rights, and the risk of infringement of such rights, are entirely their own responsibility.

This standard is subject to revision at any time by the responsible technical committee and must be reviewed every five years and if not revised, either reapproved or withdrawn. Your comments are invited either for revision of this standard or for additional standards and should be addressed to ASTM Headquarters. Your comments will receive careful consideration at a meeting of the responsible technical committee, which you may attend. If you feel that your comments have not received a fair hearing you should make your views known to the ASTM Committee on Standards, at the address shown below.

This standard is copyrighted by ASTM, 100 Barr Harbor Drive, PO Box C700, West Conshohocken, PA 19428-2959, United States. Individual reprints (single or multiple copies) of this standard may be obtained by contacting ASTM at the above address or at 610-832-9585 (phone), 610-832-9555 (fax), or service@astm.org (e-mail); or through the ASTM website (www.astm.org).