



# Test Method for Determining Tensile Adhesion Properties of Sealants When Used in Exterior Insulation and Finish Systems (EIFS) Joints<sup>1</sup>

This standard is issued under the fixed designation C 1382; the number immediately following the designation indicates the year of original adoption or, in the case of revision, the year of last revision. A number in parentheses indicates the year of last reapproval. A superscript epsilon ( $\epsilon$ ) indicates an editorial change since the last revision or reapproval.

## 1. Scope

1.1 This test method describes a laboratory procedure for measuring tensile adhesion properties of sealants to exterior insulation and finish systems (EIFS) under dry, wet, frozen, heat-aged, and UV/condensation-aged conditions.

1.2 The values stated in SI (metric) units are to be regarded as the standard. The inch-pound values given in parentheses are provided for information only.

1.3 *This standard does not purport to address all of the safety concerns, if any, associated with its use. It is the responsibility of the user of this standard to establish appropriate safety and health practices and determine the applicability of regulatory limitations prior to use.*

1.4 The committee with jurisdiction over this standard is not aware of any comparable standards published by other organizations.

## 2. Referenced Documents

### 2.1 ASTM Standards:

C 717 Terminology of Building Seals and Sealants<sup>2</sup>

C 1135 Test Method for Determining Tensile Adhesion Properties of Structural Sealants<sup>2</sup>

E 631 Terminology of Building Constructions<sup>3</sup>

G 53 Practice for Operating Light- and Water-Exposure Apparatus (Fluorescent UV-Condensation Type) for Exposure of Nonmetallic Materials<sup>4</sup>

## 3. Terminology

3.1 *Definitions*—refer to Terminology C 717 for definitions of the following terms used in this test method: adhesion failure, cohesive failure, primer, sealant, and substrate.

3.2 *Description of Terms Specific to This Standard*—refer to Terminology E 631 for definitions of the following terms used in this test method: base coat, EIFS, and finish coat.

## 4. Summary of Test Method

4.1 This test method is a modification of Test Method C 1135. Preliminary testing using Test Method C 794 may be helpful as a screen test to determine dry adhesion capabilities and priming requirements before proceeding with this test. This test is performed after the specimen assemblies are subjected to a variety of conditions that artificially accelerate the effect of weathering impact on the sealant-to-EIFS bond. The conditioning employed in this test does not necessarily address all field conditions.

## 5. Significance and Use

5.1 EIFS are barrier-type systems that must be weather-proofed to prevent the passage of moisture, air, dust, heat, and cold from entering a structure.

5.2 This test method is intended to determine the adhesion properties of the sealant with the EIFS substrate as determined by its tensile adhesive properties for dry, wet, frozen, heat-aged, and UV/condensation-aged conditions.

## 6. Apparatus and Materials

6.1 *Tensile Testing Machine*—Capable of producing a tensile load on the specimen at the rate of  $50 \pm 5$  mm ( $2.0 \pm 0.20$  in.)/min., and with a recording chart to show stress/strain values (tensile modulus).

6.1.1 *Fixed Member*—A fixed or essentially stationary member carrying one grip.

6.1.2 *Movable Member*—A movable member carrying a second grip.

6.1.3 *Grips*—The grips should be suitable to firmly grasp the test fixture that holds the test specimen and should be designed to eliminate eccentric specimen loading. Specimen loading should be perpendicular to the substrate/sealant interfaces. For alignment purposes, each grip shall have a swivel or universal joint at the end nearest to the specimen.

6.1.4 *Grip Fixture*—A fixture capable of being held by the grips and furnishing a tensile force to the sealant specimen.

6.2 *Spatulas*—For use in applying sealant.

6.3 *Caulking Gun*—For extruding sealant from cartridges, when applicable.

6.4 *Primer*, if applicable.

<sup>1</sup> This test method is under the jurisdiction of C24 on Building Seals and Sealants and is the direct responsibility of Subcommittee C24.30 on Adhesion.

Current edition approved Jan. 10, 2002. Published March 2002. Originally published as C 1382–97. Last previous edition C 1382–97.

<sup>2</sup> *Annual Book of ASTM Standards*, Vol 04.07.

<sup>3</sup> *Annual Book of ASTM Standards*, Vol 04.11.

<sup>4</sup> *Annual Book of ASTM Standards*, Vol 14.02.

6.5 Sealant.

6.6 Spacer—One piece of spacer made from polytetrafluorethylene (PTFE) or a suitable rigid material shall be used to which the test sealant will not bond.

6.7 Knife, with sharp razor-type blade.

6.8 Masking Tape.

6.9 EIFS substrate, as identified in 10.1.5.

6.10 Rigid substrate, for applying EIFS coating in the peel adhesion test.

6.11 Waterproof membrane, such as molten paraffin.

6.12 Freezer,  $-18 \pm 2^\circ\text{C}$  ( $0 \pm 3.6^\circ\text{F}$ ).

6.13 Oven,  $70 \pm 2^\circ\text{C}$  ( $158 \pm 3.6^\circ\text{F}$ ).

6.14 UV/condensation, in accordance with Practice G 53.

7. Test Specimens

7.1 Two (2) EIFS samples are required for each test specimen assembly as shown in Fig. 1. The EIFS sample size shall be determined by the size of the test machine grips, yet they must be a minimum of 25 by 75 mm (1 by 3 in.). It may be necessary to cut the EIFS substrate into rectangles appropriately sized for the test. If cutting is required, the EIFS must be configured such that three of the four long ends of the EIFS

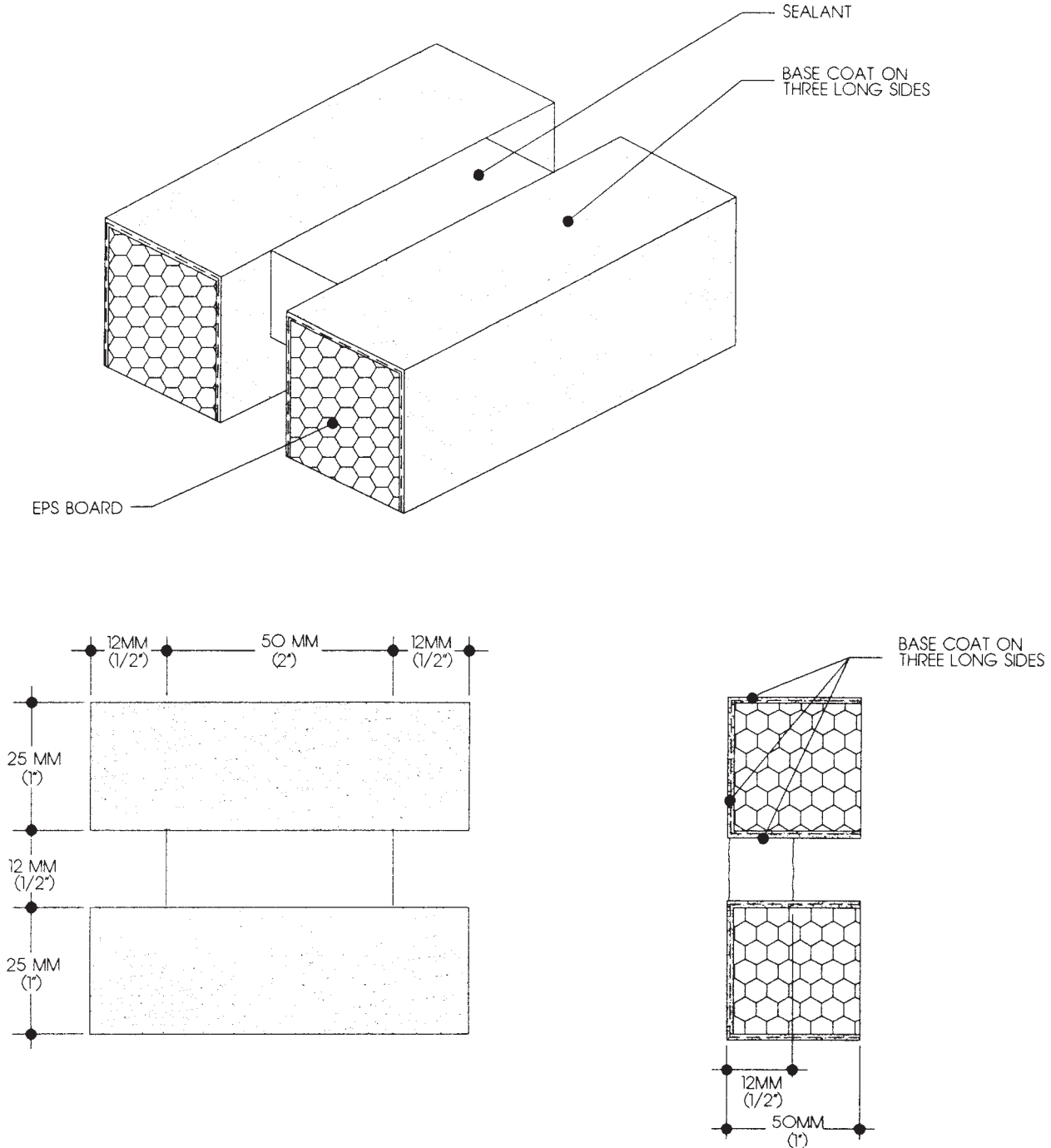

FIG. 1 Test Specimen Assembly

substrate will be coated with EIFS base or finish coat. The remaining long end and two short ends will be uncoated EPS board with cut edges of the EIFS coating visible. In all cases, the sealant should be applied to the EIFS finish on a long side at the edge where a coated surface continues around the corner. The sealant should not be applied on the edge where coating stops and EPS board is exposed on the adjoining corner.

7.2 The EIF system being tested must be applied over minimum 25 mm (1 in.) insulation board with coating thickness consistent with the EIFS manufacturer's requirements and allowed to cure 28 days minimum at standard conditions. Select surface to be tested (for example, EIFS primer, base coat, finish coat, etc.).

NOTE 1—Five test specimen assemblies per condition should be prepared for each sealant and substrate system being tested for a total of 25 specimens per sealant/EIFS substrate combination. It may be beneficial to prepare up to five extra specimen assemblies in the event one or more samples is unusable.

7.3 Prior to assembling the test specimens, clean the surfaces to be sealed with a clean, dry, lint-free cloth or soft, nonmetallic bristle brush.

7.4 Prime surfaces (if applicable) to be sealed with appropriate primer as recommended by the sealant manufacturer. Do not allow primer to contact EPS insulation. Allow primer to dry as specified by sealant manufacturer.

7.5 Provide a 12 mm (~½ in.) spacer to form a sealant cavity centered on the test specimen measuring 12 by 12 by 50 mm (½ by ½ by 2 in.) between the test samples. (See Fig. 1.)

7.6 Sandwich the spacer between the two test samples and secure them together with clamps or mechanical devices.

7.7 Fill each set of five test specimen assemblies with the sealant being tested and immediately strike off any excess sealant.

7.8 Identify each of the five test specimens.

7.9 Cure specimens under one of the following cycles:

7.9.1 *Standard Conditions*— $23 \pm 2^\circ\text{C}$  ( $73.4 \pm 3.6^\circ\text{F}$ ),  $50 \pm 5\%$  relative humidity for a minimum of 21 days.

7.9.2 Alternately, cure for a total of 21 days as follows: (a) 7 days at standard conditions above; (b) 7 days at  $38 \pm 2^\circ\text{C}$  ( $100 \pm 3.6^\circ\text{F}$ ) and 95 % relative humidity; (c) 7 days at standard conditions.

7.9.3 The sealant manufacturer may request conditions other than those specified provided the temperature does not exceed  $50^\circ\text{C}$  ( $122^\circ\text{F}$ ).

## 8. Conditioning

8.1 Following completion of cure as outlined in 7.9, test samples under the following conditions:

8.1.1 *Dry/Room Temperature*—Test samples at  $23 \pm 2^\circ\text{C}$  ( $73.4 \pm 3.6^\circ\text{F}$ ),  $50 \pm 5\%$  relative humidity.

8.1.2 *Water Immersion*:

8.1.2.1 Prior to immersing samples, seal perimeter edges and the outer (nonsealant surface face) of each EIFS component of the test specimen with a waterproof membrane such as molten paraffin. Do not heat the paraffin above  $65^\circ\text{C}$  ( $150^\circ\text{F}$ ) in order to avoid damage to EPS insulation. The interior facing surfaces that create the 12-mm (½ in.) gap will not be waxed.

(See Fig. 2) Multiple dips or turns may be required to adequately cover the substrate.

8.1.2.2 Completely immerse 5 test specimen assemblies for 7 days. Weight or attach the samples so that they are completely covered to a depth of 50 mm (2 in.) with water. Test within 5 min of removal from water.

8.1.3 *Frozen*—Condition five test specimen assemblies in a  $-18 \pm 2^\circ\text{C}$  ( $0 \pm 3.6^\circ\text{F}$ ) freezer for 24 h. Remove assemblies one at a time. Test each assembly within 5 min of removal from the freezer.

8.1.4 *Heat Conditioning*—Condition five test specimen assemblies in a  $70 \pm 2^\circ\text{C}$  ( $158 \pm 3.6^\circ\text{F}$ ) oven for 24 h. Remove assemblies one at a time. Test each assembly within 5 min of removal from the oven.

8.1.5 UV/condensation in accordance with Test Method G 53—Condition five test specimen assemblies in UV condensation for 2500 h using the UV-A340 type bulbs and cycles of 8 h UV at  $60^\circ\text{C}$ , 4 h condensation at  $50^\circ\text{C}$ . Position the assemblies with the weathering surface of the sealant facing the bulbs. (See Fig. 3.) After exposure, condition samples in laboratory for 16 h minimum at standard conditions.

## 9. Procedure

9.1 Measure and record the initial distance between the EIFS substrates prior to loading.

9.2 Place the test specimen assembly in the grips of the tensile test machine and test at a rate of  $50 \text{ mm} \pm 5 \text{ mm}$  ( $2.0 \pm 0.20 \text{ in.}/\text{min}$ ).

9.3 Record the tensile load at 10, 25, 50, and 100 % elongation (based on measurement obtained in 9.1) Other coincidence points may be recorded as desired. Stop the extension at 100 % elongation. If failure occurs prior to 100 % elongation, record elongation and tensile load at failure point.

9.4 Measure and record adhesive or cohesive failures, if either occurs.

## 10. Report

10.1 The report shall include the following information for each sample tested:

10.1.1 Sample identification,

10.1.2 Sealant identification (single versus multicomponent, color, chemical category, etc.),

10.1.3 Actual conditioning time as used in 8.1,

10.1.4 Surface preparation (if used, primer identification),

10.1.5 EIFS identification including base coat thickness, type, and amount of mix water. Describe surface tested (such as EIFS primer, base coat, finish coat, etc.),

10.1.6 Tensile Adhesion Testing Data:

10.1.6.1 Tensile load in Newton's (pounds-force) at each elongation point described in 9.3.

10.1.6.2 The percentage loss in bond and cohesion for each sample tested. Note failure mode.

10.1.6.3 Variation, if any, from the test procedure,

10.1.7 Freezer temperature, and

10.1.8 Actual time (number of hours) in UV/condensation apparatus.

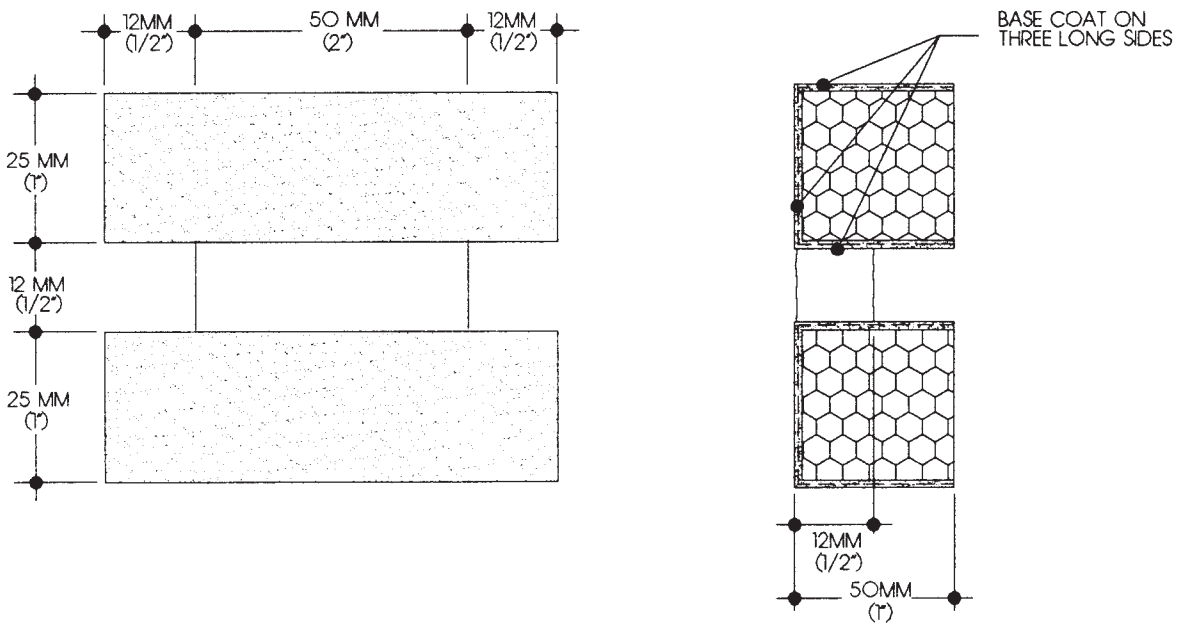
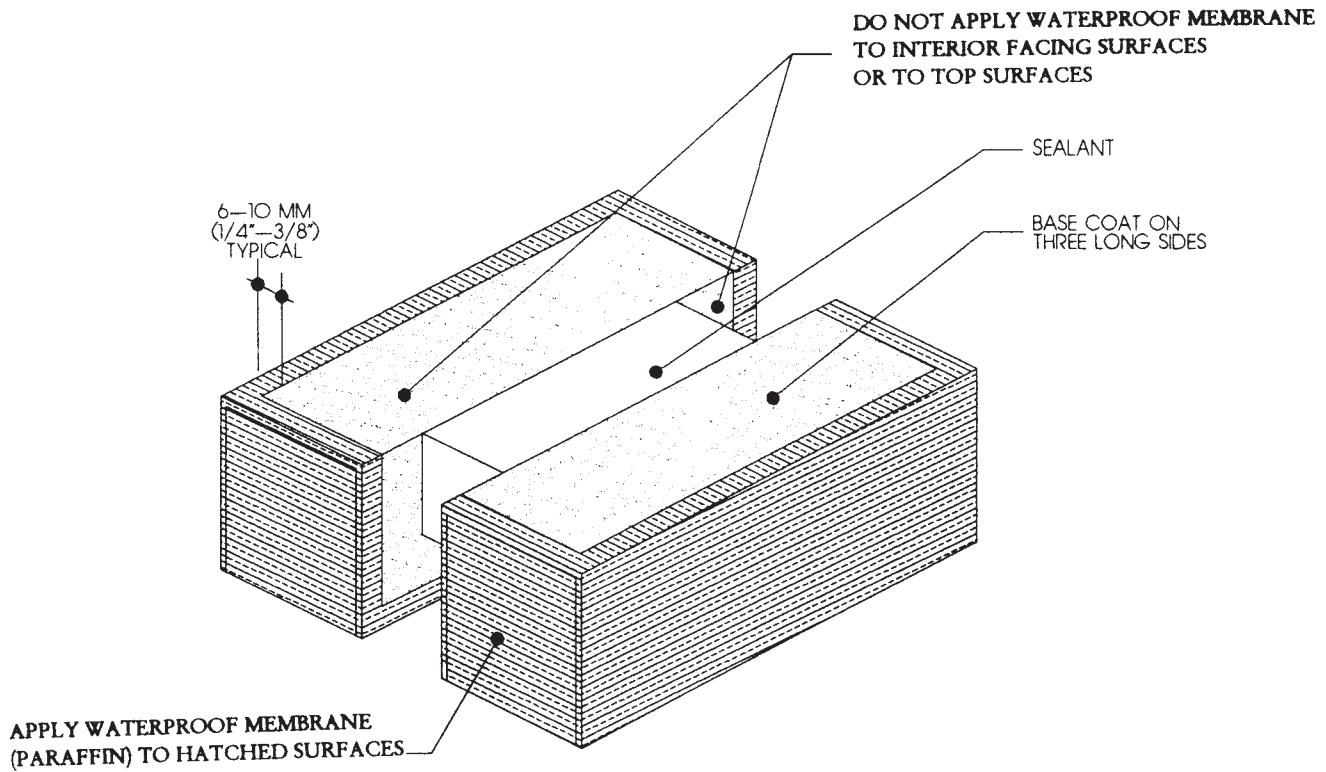

FIG. 2 Test Specimen Assembly of Water Immersion Samples

### 11. Precision and Bias

The precision and bias of this test method has not yet been determined.

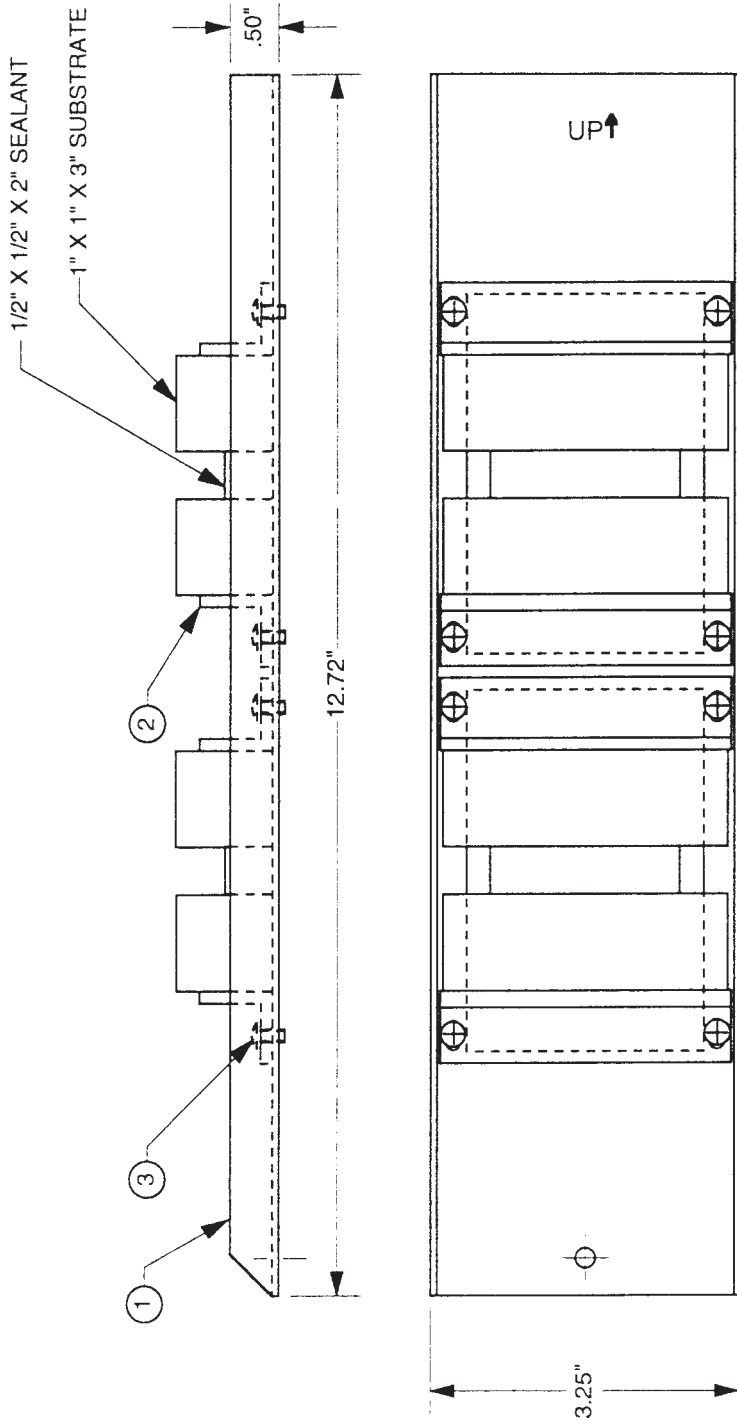

FIG. 3 Position of Test Specimens for UV/Condensation Exposure

*ASTM International takes no position respecting the validity of any patent rights asserted in connection with any item mentioned in this standard. Users of this standard are expressly advised that determination of the validity of any such patent rights, and the risk of infringement of such rights, are entirely their own responsibility.*

*This standard is subject to revision at any time by the responsible technical committee and must be reviewed every five years and if not revised, either reapproved or withdrawn. Your comments are invited either for revision of this standard or for additional standards and should be addressed to ASTM International Headquarters. Your comments will receive careful consideration at a meeting of the responsible technical committee, which you may attend. If you feel that your comments have not received a fair hearing you should make your views known to the ASTM Committee on Standards, at the address shown below.*

*This standard is copyrighted by ASTM International, 100 Barr Harbor Drive, PO Box C700, West Conshohocken, PA 19428-2959, United States. Individual reprints (single or multiple copies) of this standard may be obtained by contacting ASTM at the above address or at 610-832-9585 (phone), 610-832-9555 (fax), or [service@astm.org](mailto:service@astm.org) (e-mail); or through the ASTM website ([www.astm.org](http://www.astm.org)).*